



**Bundesstelle für Seeunfalluntersuchung**  
**Federal Bureau of Maritime Casualty Investigation**  
Federal Higher Authority subordinated to the Ministry of Transport  
and Digital Infrastructure

## **Investigation Report 44/16**

**Very Serious Marine Casualty**

**Foundering of the fishing vessel CONDOR  
on 6 February 2016 about 3.5 nm east of the  
Baltic Sea Island of Fehmarn**

5 October 2017

The investigation was conducted in conformity with the Law to improve safety of shipping by investigating marine casualties and other incidents (Maritime Safety Investigation Law – SUG). According to said Law, the sole objective of this investigation is to prevent future accidents. This investigation does not serve to ascertain fault, liability or claims (Article 9(2) SUG).

This report should not be used in court proceedings or proceedings of the Maritime Board. Reference is made to Article 34(4) SUG.

The German text shall prevail in the interpretation of this investigation report.

Issued by:  
Bundesstelle für Seeunfalluntersuchung – BSU  
(Federal Bureau of Maritime Casualty Investigation)  
Bernhard-Nocht-Str. 78  
20359 Hamburg  
Germany



Director: Ulf Kaspera  
Phone: +49 40 3190 8300  
posteingang-bsu@bsh.de

Fax: +49 40 3190 8340  
[www.bsu-bund.de](http://www.bsu-bund.de)

## Table of Contents

1	SUMMARY.....	11
2	FACTUAL INFORMATION.....	13
3	COURSE OF THE ACCIDENT AND INVESTIGATION .....	16
	3.1 Course of the accident .....	16
	3.1.1 Events prior to the accident.....	16
	3.1.2 Events after the accident.....	16
	3.2 Consequences of the accident .....	17
	3.3 Investigation .....	17
	3.3.1 Course, sources and material particulars .....	17
	3.3.2 FV CONDOR (basic information) .....	26
	3.3.2.1 General information.....	26
	3.3.2.2 GRP coating .....	27
	3.3.2.3 Stability documents .....	28
	3.3.2.4 Rescue and safety equipment.....	29
	3.3.2.5 Scrapping the fishing vessel.....	29
	3.3.3 Fishing vessel dive report.....	30
	3.3.4 Report of the salvage company.....	31
	3.3.5 Visual inspection of the wreck after she arrived in Warnemünde .....	34
	3.3.6 Weather conditions (DWD report) .....	36
	3.3.7 Professional experience of the two crew members .....	37
	3.3.8 Workload .....	37
	3.3.9 Alcohol .....	37
	3.3.10 Autopsy of the victims and cause of death .....	37
	3.3.11 EPIRB .....	38
	3.3.11.1 Investigation of the BSU .....	38
	3.3.11.2 Investigation by the manufacturer .....	41
	3.3.12 Liferaft .....	45
	3.3.12.1 General preliminary remarks and initial findings.....	45
	3.3.12.2 Investigation of the BSU .....	48
	3.3.13 Reconstruction of the course of the voyage on the day of the accident .....	63
	3.3.13.1 Preliminary remarks .....	63
	3.3.13.2 Analysis of the BLE antenna .....	65
	3.3.13.3 Analysis of the radar image recording from the VTS.....	73
	3.3.14 Investigation of the engine and the winch control.....	81
	3.3.14.1 Preliminary remarks .....	81
	3.3.14.2 Opinion of Professor Diederichs.....	81
	3.3.15 Assessment of the FV CONDOR's hydrostatic properties.....	94
	3.3.15.1 Preliminary remarks .....	94
	3.3.15.2 Opinion of Dipl.-Ing. Jan Hatecke .....	95
4	ANALYSIS .....	124
	4.1 Reconstruction of the courses of the voyage and accident .....	124

4.2	Failure of the liferaft.....	125
4.3	Failure of the EPIRB.....	126
4.4	Identification of the primary cause of the accident.....	127
4.4.1	Engine, rudder and winches.....	128
4.4.2	Stability of the fishing vessel.....	128
4.4.2.1	Assessment of the fishing vessel's stability at the time of the accident.....	128
4.4.2.2	Planned renewal of the proof of stability and the Guideline for fishing vessels.....	130
4.5	Other underlying conditions.....	132
4.5.1	Fishing vessel's maintenance status and certificates.....	132
4.5.2	Qualifications and experience of the crew.....	133
4.5.3	Fatigue and alcohol.....	133
4.5.4	Lifejacket and floatation waistcoat.....	133
5	CONCLUSIONS.....	134
5.1	Primary cause of the accident and consequences.....	134
5.2	Failure of the liferaft.....	135
5.3	Failure of the EPIRB.....	136
5.4	Use of lifejackets and floatation waistcoats.....	137
6	MEASURES TAKEN.....	139
7	SAFETY RECOMMENDATIONS.....	140
7.1	German Social Accident Insurance Institution for Commercial Transport, Postal Logistics and Telecommunication (Ship Safety Division (BG Verkehr)).....	140
7.1.1	Review of the proofs of stability for all vessels covered by the 2009 Guideline for fishing vessels.....	140
7.1.2	Review of the procedures for determining stability values.....	140
7.2	Federal Ministry of Transport and Digital Infrastructure (BMVI); German Social Accident Insurance Institution for Commercial Transport, Postal Logistics and Telecommunication (Ship Safety Division (BG Verkehr)) – review of the national body of rules applicable to fishing vessels.....	140
7.3	Federal Ministry of Transport and Digital Infrastructure (BMVI); German Social Accident Insurance Institution for Commercial Transport, Postal Logistics and Telecommunication (Ship Safety Division (BG Verkehr)) – renewal of proof of stability and photographic documentation of vessel surveys.....	141
7.4	Federal Ministry of Transport and Digital Infrastructure (BMVI) – revision of the carriage requirement for EPIRBs.....	141
7.5	Survitec Group, Deutsche Schlauchboot.....	141
	SOURCES.....	142

## Table of Figures

Figure 1: FV CONDOR.....	13
Figure 2: Scene of the accident.....	14
Figure 3: Sonar image of the wreck of the FV CONDOR .....	18
Figure 4: Floating crane SANNE A and multipurpose ship MIRA A (preparing for the salvage operation) .....	19
Figure 5: FV CONDOR immediately after the night-time salvage operation.....	20
Figure 6: Salvage convoy (sailing into Warnemünde) .....	20
Figure 7: FV CONDOR on the working deck of the MIRA A.....	21
Figure 8: FV CONDOR shortly before she was set down on the buoy yard's pier....	21
Figure 9: FV CONDOR ready for the ensuing investigation.....	22
Figure 10: 3D laser scan of the FV CONDOR by LKA Hamburg on 15 March 2016.....	23
Figure 11: Determination of individual masses when the fishing vessel was dismantled (above the wheelhouse) in September 2016.....	23
Figure 12: Special scale and device for wirelessly recording measurements.....	24
Figure 13: Non-surfaced liferaft on the FV CONDOR.....	24
Figure 14: FV CONDOR'S EPIRB.....	25
Figure 15: Cracks in the GRP coating .....	28
Figure 16: Cracks in the GRP coating (close-up) .....	28
Figure 17: Scrapping the FV CONDOR at the buoy yard (final phase).....	30
Figure 18: Opening 1 in the main deck.....	31
Figure 19: Opening 2 in the main deck (the associated cover is at the top right) .....	32
Figure 20: Access openings to the hold.....	32
Figure 21: Hole in the partition wall between the companionway and skipper's berth .....	33
Figure 22: Position of the rudder blade (unchanged during the salvage operation)..	33
Figure 23: Rudder position indicator (wheelhouse on the FV CONDOR).....	34
Figure 24: Control lever (wheelhouse on the FV CONDOR) .....	35
Figure 25: FV CONDOR – mounting position of the EPIRB .....	38
Figure 26: FV CONDOR'S EPIRB .....	39

Figure 27: FV CONDOR immediately after salvage (empty EPIRB mount visible)...	39
Figure 28: Open EPIRB mount (starboard side of fishing vessel – wheelhouse) .....	40
Figure 29: Example of a hydrostatic release unit.....	40
Figure 30: Extract 1 from the EPIRB manufacturer's assessment report.....	42
Figure 31: Extract 2 from the EPIRB manufacturer's assessment report.....	43
Figure 32: Extract 3 from the EPIRB manufacturer's assessment report.....	44
Figure 33: Position of the liferaft on board the FV CONDOR.....	45
Figure 34: Hydrostatic release unit belonging to the FV CONDOR's liferaft .....	46
Figure 35: Liferaft's mount and painter/release cord.....	46
Figure 36: Close-up of painter/release cord connection with liferaft mount .....	47
Figure 37: Empty liferaft mount (extract from the DENEb's dive video – 12 February 2016) .....	48
Figure 38: Liferaft next to the wreck of the CONDOR with line connection to the fishing vessel (extract from the DENEb's dive video – 12 February 2016) .....	48
Figure 39: FV CONDOR (arrival in Rostock; liferaft provisionally attached to the mast) .....	49
Figure 40: Information about the manufacturer and service interval on the FV CONDOR's liferaft .....	49
Figure 41: Close-up of the liferaft's container (opening for the painter/release cord).....	50
Figure 42: Liferaft before further examination.....	51
Figure 43: Information about type approval, manufacturer and technical data on the liferaft's container.....	51
Figure 44: Maximum possible extraction length of the painter/release cord .....	52
Figure 45: Painter/release cord's exit point from the container (cord cannot be pulled out with muscular force).....	53
Figure 46: First photograph after removing the top half of the container .....	54
Figure 47: Liferaft tipped carefully out of the container .....	54
Figure 48: Liferaft rotated 180° compared to Fig. 46 .....	55
Figure 49: Intended position of the opening in the container compared to position of the painter sachet after removal of the liferaft's protective plastic covering .....	55

Figure 50: Extract 1 from the service manual – manufacturer's instructions for positioning the painter sachet when packing the liferaft.....	56
Figure 51: Extract 2 from the service manual – manufacturer's instructions for positioning the painter sachet when packing the liferaft.....	57
Figure 52: Manual activation of the inflation process.....	58
Figure 53: References to serial number/manufacturer/completed services.....	59
Figure 54: Close-up of manufacturer information and serial number.....	59
Figure 55: Close-up of the service record in December 2015.....	60
Figure 56: AP35 autopilot control unit.....	63
Figure 57: RS 5310 GPS receiver .....	64
Figure 58: GP-32 GPS receiver.....	64
Figure 59: Attempt to analyse the GP-32 GPS receiver by FURUNO's service department .....	65
Figure 60: FV CONDOR's track data for 4-6 February 2016 (source: BLE) .....	66
Figure 61: Position of the BLE antenna on the FV CONDOR.....	67
Figure 62: The BLE antenna exhibiting no visible damage.....	68
Figure 63: Opened antenna housing without any traces of moisture.....	69
Figure 64: Technical preparatory measures for reading the antenna data (1).....	70
Figure 65: Technical preparatory measures for reading the antenna data (2).....	70
Figure 66: Shielding the antenna with a metal container .....	71
Figure 67: Information on the fishing vessel's last stored position before the antenna signal was interrupted (the time of foundering).....	71
Figure 68: Complete screenshot from the radar video of VTS Travemünde.....	73
Figure 69: Radar echo of the FV CONDOR at 112836.....	73
Figure 70: Radar echo of the FV CONDOR at 113001.....	74
Figure 71: Radar echo of the FV CONDOR at 113031.....	74
Figure 72: Radar echo of the FV CONDOR at 113101.....	74
Figure 73: Radar echo of the FV CONDOR at 113144.....	74
Figure 74: Radar echo of the FV CONDOR at 113232.....	75
Figure 75: Radar echo of the FV CONDOR at 113307.....	75
Figure 76: Radar echo of the FV CONDOR at 113400.....	75
Figure 77: Radar echo of the FV CONDOR at 113501.....	75
Figure 78: Radar echo of the FV CONDOR at 113537.....	76

Figure 79: Radar echo of the FV CONDOR at 113601 .....	76
Figure 80: Radar echo of the FV CONDOR at 113616 .....	76
Figure 81: Radar echo of the FV CONDOR at 113641 .....	76
Figure 82: Radar echo of the FV CONDOR at 113725 .....	77
Figure 83: Radar echo of the FV CONDOR at 114113 .....	77
Figure 84: Radar echo of the FV CONDOR at 114134 .....	77
Figure 85: Radar echo of the FV CONDOR at 114146 .....	77
Figure 86: Drawing of the fishing equipment (trawling) .....	82
Figure 87: Sectional view of the reversing gear unit .....	83
Figure 88: Diagram of engine and transmission control system .....	84
Figure 89: Diagram of the reversing gear .....	84
Figure 90: Diagram of the steering gear .....	85
Figure 91: Diagram of the winch control system .....	86
Figure 92: Traction cable with pulley and injection pump .....	87
Figure 93: Cooling water pumps and piping .....	88
Figure 94: Transmission block with control unit .....	88
Figure 95: Control system in the bridge console .....	89
Figure 96: Hydraulic pump and steering gear control valve .....	89
Figure 97: Winch hydraulic pump with drive .....	90
Figure 98: Pressure control valve and hydraulic lines on deck .....	90
Figure 99: Winch control position on deck .....	91
Figure 100: 4/3-way valve surface for the trawl winch .....	91
Figure 101: Electrical winch control .....	92
Figure 102: Position of the changeover valves in the net-winding winch lines .....	92
Figure 103: Destroyed hoses and pipes on the port railing .....	93
Figure 104: FV CONDOR's fish hold (not used on the day of the accident) .....	95
Figure 105: Tank opening on the starboard side .....	96
Figure 106: Absent bolting between the deck and fish hold .....	96
Figure 107: Inlet air flap at forward edge of wheelhouse .....	96
Figure 108: Position of the rudder blade at the time of the accident .....	97
Figure 109: Usual position of the fish chute on an older photograph .....	97
Figure 110: Freeing port openings on the port side .....	97



Figure 111: Net's codend filled with fish immediately after the fishing vessel was salvaged .....	98
Figure 112: 3D laser scan of the FV CONDOR by LKA Hamburg .....	99
Figure 113: Analysis of the scan process (top view).....	99
Figure 114: Analysis of the scan process (port side from the bow) .....	100
Figure 115: Analysis of the scan process (starboard side from the stern) .....	100
Figure 116: Information about the hydrostatic software used .....	101
Figure 117: MODELMAKER (the output program) .....	101
Figure 118: Weighing the entire superstructure, including toilet compartment and exhaust .....	102
Figure 119: Findings of the draught determination .....	104
Figure 120: Overview of mass determination from the waterline .....	104
Figure 121: Overview of the VCG wood mass.....	105
Figure 122: Available stowage positions A-G for fish crates on the main deck of the fishing vessel .....	107
Figure 123: Presumed stowage positions of the filled fish crates on the day of the accident .....	107
Figure 124: Stowage space for empty fish crates port side of the superstructure ..	108
Figure 125: Storage spaces (hurdles) for the non-slaughtered catch on the main deck .....	109
Figure 126: Determination of the centre of gravity 'Fish in codend' .....	109
Figure 127: Reconstruction of the codend's position .....	110
Figure 128: Components of force due to fish in the net.....	110
Figure 129: Stability calculation at the time of the accident .....	113
Figure 130: Righting lever as a function of heeling angle .....	113
Figure 131: Righting lever arm curve calculated for the FV CONDOR on the day of the accident .....	113
Figure 132: Impact on the righting lever arm curve of water ingress in the fish hold .....	114
Figure 133: Impact on the righting lever arm curve of water ingress in the engine room .....	115
Figure 134: FV CONDOR stability calculation – load case 1 .....	118
Figure 135: Righting lever arm curve of the FV CONDOR – load case 1 .....	118

---

Figure 136: Comparison between the Guideline's stability requirements and values of the FV CONDOR – load case 1 .....	118
Figure 137: FV CONDOR stability calculation – load case 2 .....	119
Figure 138: Righting lever arm curve of the FV CONDOR – load case 2 .....	119
Figure 139: Comparison between the Guideline's stability requirements and values of the FV CONDOR – load case 2 .....	119
Figure 140: FV CONDOR stability calculation – load case 3 .....	120
Figure 141: Righting lever arm curve of the FV CONDOR – load case 3 .....	120
Figure 142: Comparison between the Guideline's stability requirements and values of the FV CONDOR – load case 3 .....	120
Figure 143: FV CONDOR stability calculation – load case 4 .....	121
Figure 144: Righting lever arm curve of the FV CONDOR – load case 4 .....	121
Figure 145: Comparison between the Guideline's stability requirements and values of the FV CONDOR – load case 4 .....	121

## 1 Summary

On 6 February 2016, the German fishing vessel CONDOR foundered about 3.5 nm east of the Baltic Sea island of Fehmarn. The two fishermen on board drowned in the Baltic Sea.

The fishing vessel sailed out of her home port (Burgstaaken on the island of Fehmarn) for a one-day fishing voyage east of the island of Fehmarn at 0647<sup>1</sup> on the day of the accident. At about 1130, the CONDOR started her voyage home after several highly productive hauls<sup>2</sup>, which resulted in an estimated 3,000 kg of fish being deposited on her deck. The fishing vessel capsized a few minutes later and foundered at 1136 in wind force 5 Bft and a short-wave wind sea of about 1 m in the Baltic Sea, which was about 3°C and 20 m deep at the scene of the accident.

After the fishing vessel had still not arrived several hours after her expected return to Burgstaaken, the Fischer-genossenschaft Fehmarn – Erzeugergemeinschaft eG (fishermen's cooperative) notified the waterway police (WSP). The latter then immediately initiated an extensive search for the missing vessel and her crew.

At about 2000, the WSP boat FEHMARN discovered items presumably from the missing vessel (fish crates and ropes) in the vicinity of the CONDOR's last known position. Shortly afterwards, the crew of a helicopter involved in the search and rescue operation identified two people floating lifeless in the water in the immediate vicinity. After their recovery and transport to Burgstaaken, they were unequivocally identified as the two crew members of the FV CONDOR. It was not possible to locate the actual fishing vessel and therefore assumed that she had foundered.

The BSH<sup>3</sup> ship DENEK, which was tasked with searching for the foundered fishing vessel, located the wreck of the CONDOR on the sandy bottom of the Baltic Sea on 9 February 2016.

The subsequent dives by divers from the police and the BSH did not provide any evidence as to the cause of the fishing vessel foundering. As far as could be seen, she lay on her starboard side on the seabed and was largely undamaged.

Since it was not necessary to salvage the fishing vessel for the purposes of the police investigation into the accident, any environmental legislation or from the perspective of the river or shipping police, the BSU decided to salvage the CONDOR in the course of the maritime safety investigation, which was set in motion immediately after the accident was reported.

---

<sup>1</sup> Unless stated otherwise, all times shown in this report are local: MEZ (UTC + 1 hour).

<sup>2</sup> Haul: Term used in fishing that describes the process of taking on board a net filled with fish.

<sup>3</sup> BSH: Federal Maritime and Hydrographic Agency.

After extensive preparatory work, the salvage company (Baltic Taucherei- und Bergungsbetrieb Rostock GmbH) appointed by the BSU managed to raise the fishing vessel out of the water on the evening of 7 March 2016.

The fishing vessel was put ashore at the site of the Warnemünde/Hohe Düne buoy yard (outlying area of Waterways and Shipping Office (WSA) Stralsund) on 8 March 2016. Thanks to the cautious handling of the fishing vessel by the salvage company when she was raised, transported, and put ashore, she was available to the BSU for the necessary investigative measures in a largely intact condition in the months that ensued.

## 2 FACTUAL INFORMATION

### 2.1 Photo of the FV CONDOR



Figure 1: FV CONDOR

### 2.2 Ship particulars: FV CONDOR

Name of ship:	CONDOR
Type of ship:	Fishing vessel
Nationality/Flag:	Germany
Port of registry:	Burgstaaken (Fehmarn)
Fisheries code:	SB 14
Call sign:	DKAV
Year built:	1943
Shipyard:	Wendlandt Werft, Wollin (West Pomerania)
Length overall:	16.10 m
Breadth overall:	5.10 m
Draught (max.):	2.40 m
Gross tonnage:	35
Engine rating:	206 kW
Main engine:	MAN D2876 diesel engine
(Service) speed (max.):	8 kts
Hull material:	Wood (GRP coating)
Crew (on the day of the accident):	2

### 2.3 Voyage particulars: FV CONDOR

Port of departure: Planned port of call: Type of voyage:  Draught at time of accident: Manning:	Burgstaaken (island of Fehmarn, Germany) Burgstaaken (island of Fehmarn, Germany) Coastal fishing east of the island of Fehmarn (one-day fishing voyage)  No details 2
--	--

### 2.4 Marine casualty information

Type of accident: Date, time: Location: Latitude/Longitude: Ship operation and voyage segment: Consequences:	Very serious marine casualty 06/02/2016 at about 1136 CET Baltic Sea, 3.5 nm east of Fehmarn-Staberhuk Approximately $\phi$ 54°25.4'N $\lambda$ 011°24.0'E Returning home after fishing Fishing vessel foundered and both crew members lost their life
--	--

Extract from Navigational Chart No 36 (INT 1352, Travemünde to Gedser Odde), BSH

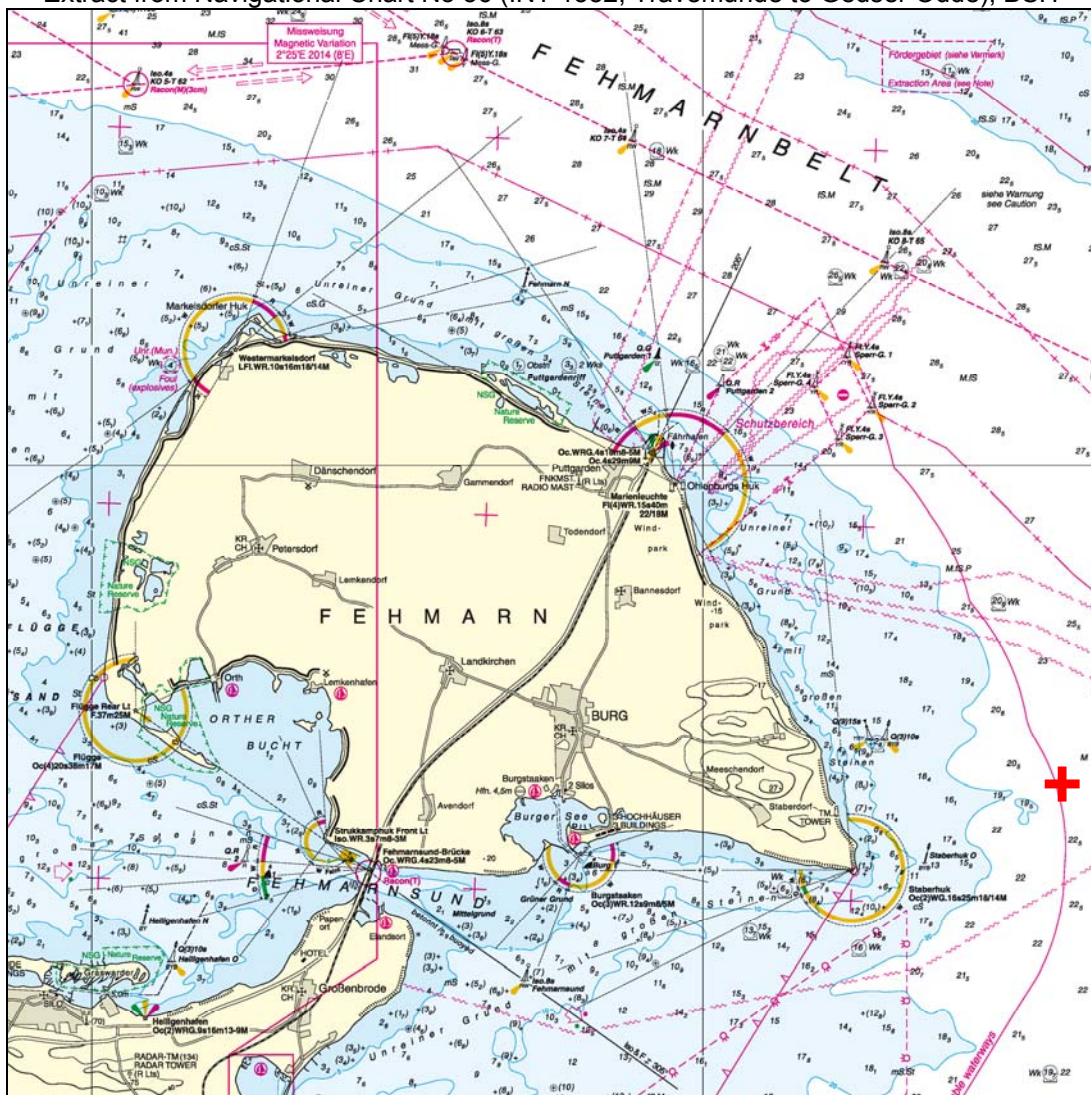


Figure 2: Scene of the accident

## 2.5 Shore authority involvement and emergency response

Agencies involved:	WSP Schleswig-Holstein, MRCC <sup>4</sup> Bremen, DGzRS <sup>5</sup> , federal police
Resources used:	WSP boat FEHMARN, federal police boat NEUSTRELITZ, federal police helicopter, search and rescue cruisers BREMEN and HANS HACKMACK, FV FALKLAND
Actions taken:	Immediate initiation of search and rescue operation from the water and by helicopter, radio-based localisation measures (AIS, VMS <sup>6</sup> and mobile radio) after receipt of the missing persons report
Results achieved:	Discovery and subsequent recovery of the two lifeless crew members floating in the water

<sup>4</sup> MRCC: Maritime Rescue Co-ordination Centre.

<sup>5</sup> DGzRS: German Maritime Search and Rescue Association.

<sup>6</sup> VMS: Vessel monitoring system (a satellite-based monitoring system for fishing vessels).

### **3 COURSE OF THE ACCIDENT AND INVESTIGATION**

#### **3.1 Course of the accident**

##### **3.1.1 Events prior to the accident**

The FV CONDOR was manned by two people in the usual manner and sailed out of the port of Burgstaaken at about 0647 in moderate weather<sup>7</sup> for a one-day fishing voyage north-east of Fehmarn-Staberhuk on the day of the accident. The net was set several times in the course of the morning. All in all, a large amount of fish was deposited on the main deck of the fishing vessel, which was located in front of the wheelhouse. The fish were sorted, slaughtered and put into crates both while fishing was ongoing and during breaks. The fish that were not yet processed due to time constraints were deposited on deck, as were the crates. The fish hold beneath the main deck was not used.

The final catch of the day was taken on board from about 1120 onwards. The crew restricted this task to hauling in the codend (end of the net in which the catch collects) so that one part hung above the deck unopened and filled with fish. The other part of the net was in the water on the starboard side of the fishing vessel with the remaining quantity of fish from the last haul.

At about 1130, the skipper of the fishing vessel used his mobile phone to advise his colleagues at the fishermen's cooperative that he was returning to the home port and given the highly productive catch asked for assistance with slaughtering the fish.

Immediately afterwards, the CONDOR got underway and began to turn onto a course for Fehmarn with a hard to starboard rudder position, while increasing speed at the same time.

While in the turning circle, the fishing vessel lost speed abruptly at about 1135. The fishing vessel capsized on her port side and foundered in the Baltic Sea during the ensuing seven minutes.

The two crew members, who were wearing neither lifejacket nor floatation waistcoat, did not have enough time to make a distress call or fire distress signals. They fell into the water and drowned in the Baltic Sea at a point in time that could no longer be determined. The foundering vessel dragged the automatically inflatable liferaft and emergency position-indicating radio beacon (EPIRB) carried on board into the depths, even though both items of safety equipment should have floated to the surface.

##### **3.1.2 Events after the accident**

The accident initially went completely unnoticed because the EPIRB failed to activate and for lack of eyewitnesses, in particular.

---

<sup>7</sup> See the comments in section 3.3.6 of this investigation report for particulars.



Since the fishing vessel had failed to return to port for several hours after the notified 1230, the fishermen's cooperative informed the WSP coastal boat FEHMARN at 1750. Attempts made from there to reach the crew by phone or locate the vessel via AIS and/or the satellite-based monitoring system for fishing vessels failed.

At 1805, the fishing vessel FALKLAND informed the WSP that she had reportedly sailed out of Burgstaaken to head for the CONDOR's last known position. The WSP forwarded this position to MRCC Bremen.

MRCC Bremen tried unsuccessfully to call the CONDOR on VHF channel 16. More and more vessels took part in the search for the fishing vessel and her crew in the ensuing period. Inter alia, the federal police boat NEUSTRELITZ, the search and rescue cruisers BREMEN and HANS HACKMACK, and a federal police helicopter were involved in the mission. The search focused on the last presumed position of the CONDOR, as communicated by the fishermen's cooperative.

A person floating lifeless in the water was discovered near this position by the helicopter involved in the search shortly after 2000 and recovered by the crew of the BREMEN at 2030. At 2050, another lifeless person was sighted from the helicopter and recovered by the HANS HACKMACK.

MRCC Bremen then aborted the search and rescue mission at 2055. Relatives of the two crew members involved in the accident confirmed their identity in the port of Burgstaaken.

The FV CONDOR was initially nowhere to be found and finally located on the Baltic Sea floor by the BSH ship DENEK on 9 February 2016.

### **3.2 Consequences of the accident**

The very serious marine casualty involving the FV CONDOR claimed the lives of both crew members. The wreck of the fishing vessel was salvaged on behalf of the BSU late in the evening of 7 March 2016 in the interest of the maritime safety investigation and scrapped upon completion of the investigation in September 2016, as a repair was not economically viable.

### **3.3 Investigation**

#### **3.3.1 Course, sources and material particulars**

WSP Station Lübeck notified the BSU by phone about the presumed foundering of the FV CONDOR a few hours after the accident. In the hours and days that followed, the BSH, WSP Lübeck, WSA Lübeck and its subordinate unit Vessel Traffic Service (VTS) Travemünde initially focused their efforts on locating the wreck of the foundered fishing vessel.

The BSU maintained close contact with the above agencies from the outset and was promptly kept up to date on the latest developments.

It was possible to isolate a presumed position at which the fishing vessel foundered by items of her equipment floating on the surface of the water, which were discovered during the search and rescue operation. Further evidence as to the approximate foundering position was delivered by localisation of each crew member's mobile phone<sup>8</sup> at the instigation of the WSP and especially the analysis of VTS Travemünde's radar image recording. One final pointer for the scene of the accident then emerged via a report from a Danish fishing vessel. Her trawl had snagged on an obstacle in the area of the CONDOR's last known radar position, which on the merits of the case could only be her wreck.

The BSH's survey, wreck search and research vessel DENEK was dispatched to the presumed scene of the accident as a consequence of this and located the wreck of the FV CONDOR at a depth of about 18 m on the sandy seabed of the Baltic Sea at midday on 9 February 2016 (see **Fig. 3** below).



**Figure 3: Sonar image of the wreck of the FV CONDOR<sup>9</sup>**

Police divers and divers from the DENEK made several dives on the wreck of the fishing vessel on 11 and 12 February 2016. The BSU was promptly sent the video recordings, including some in high-resolution, that were made in the process.

An initial analysis of these recordings and the reports prepared by the divers allowed no conclusions as to the specific cause of the foundering of the fishing vessel, which – as far as was evident – lay on the seabed on her starboard side largely undamaged. Consequently, it was necessary to salvage the fishing vessel to reliably clarify the cause of the accident.

<sup>8</sup> Note: Following a judicial order, the network operators notified the WSP of the sector and time of the last radio contact of each mobile phone.

<sup>9</sup> Source: BSH report on the localisation of and dive on the FV CONDOR of 12 February 2016.

With regard to the inquiry into the fatalities opened by the Kiel Public Prosecutor's Office ex officio after the accident, it advised the BSU that it did not intend to salvage the fishing vessel. WSA Lübeck also decided very quickly that the specific position of the wreck of the CONDOR did not necessitate or warrant a salvage or imposing a corresponding condition on her owner. For the purposes of traffic control, it was reportedly sufficient to mark the position of the wreck in the official navigational charts.

Accordingly, the BSU was the only body for which the salvage of the fishing vessel was essential based on its legal mandate to investigate. After researching the market, Baltic Taucherei- und Bergungsbetrieb Rostock GmbH was commissioned with carrying out this project, in which it was hugely important to salvage the fishing vessel from the Baltic Sea and place her ashore without any major salvage damage for further investigation. The salvage order included a requirement to document the entire process of raising the wreck. WSA Stralsund made the buoy yard in Warnemünde/Hohe Düne, which it operates and is inaccessible to unauthorised people, available to call at and for the ensuing investigation of the fishing vessel.

After a lengthy period of preparation which covered several days and was monitored by the BSU's investigation team on board a WSP boat, the fishing vessel was lifted out of the water by the floating crane SANNE A late in the evening of 7 March 2016 and placed on the working deck of the multipurpose ship MIRA A.



**Figure 4: Floating crane SANNE A and multipurpose ship MIRA A (preparing for the salvage operation)**



**Figure 5: FV CONDOR immediately after the night-time salvage operation**

The salvage convoy set off in the direction of Rostock without delay on the night of 7-8 March 2016. The SANNE A and the MIRA A arrived in Warnemünde with the wreck of the fishing vessel at about 1000.



**Figure 6: Salvage convoy (sailing into Warnemünde)**



**Figure 7: FV CONDOR on the working deck of the MIRA A**



**Figure 8: FV CONDOR shortly before she was set down on the buoy yard's pier**



**Figure 9: FV CONDOR ready for the ensuing investigation**

The BSU investigation team's initial visual inspection of the wreck on 8 March 2016 revealed that the fishing vessel did not founder because of contact with another vessel, contact with an obstacle, fire or an explosion. The integrity of the CONDOR's shell plating also indicated that she did not founder due to water ingress, e.g. as a result of material fatigue (crack or fracture in the shell plating).<sup>10</sup>

Accordingly, the only conceivable causes of the accident were inevitably stability problems on the fishing vessel, possibly in combination with technical difficulties with the engine, steering gear or winches.

The BSU commissioned two external experts with investigating the hydrostatic and/or technical aspects requiring clarification in this matter. In addition, the Hamburg State Office of Criminal Investigation (LKA Hamburg) provided the BSU with administrative support by carrying out a 3D laser scan of the fishing vessel in the interest of a detailed survey (see **Fig. 10**).

---

<sup>10</sup> Note: The cracks in the shell plating visible in Fig. 9 are merely damage to the GRP coating applied to the fishing vessel's wooden hull for conservation purposes. (This damage was an inevitable consequence of the mechanical stress on the fishing vessel when she was lifted out of the water.)



**Figure 10: 3D laser scan of the FV CONDOR by LKA Hamburg on 15 March 2016**

An inclining test planned in the course of the stability assessment could not take place, as the locally competent WSA Stralsund made clear to the BSU that it had considerable safety concerns with regard to lowering the fishing vessel into the water temporarily, which was necessary for the test.

This meant that the BSU's expert was forced to limit his assessment of stability to calculations. In addition to the above laser measurement results, he was able to make use of mass data from various individual parts of the fishing vessel in the process. These were determined precisely using a crane scale when the fishing vessel was dismantled on the grounds of the buoy yard (see **Fig. 11 f.**).

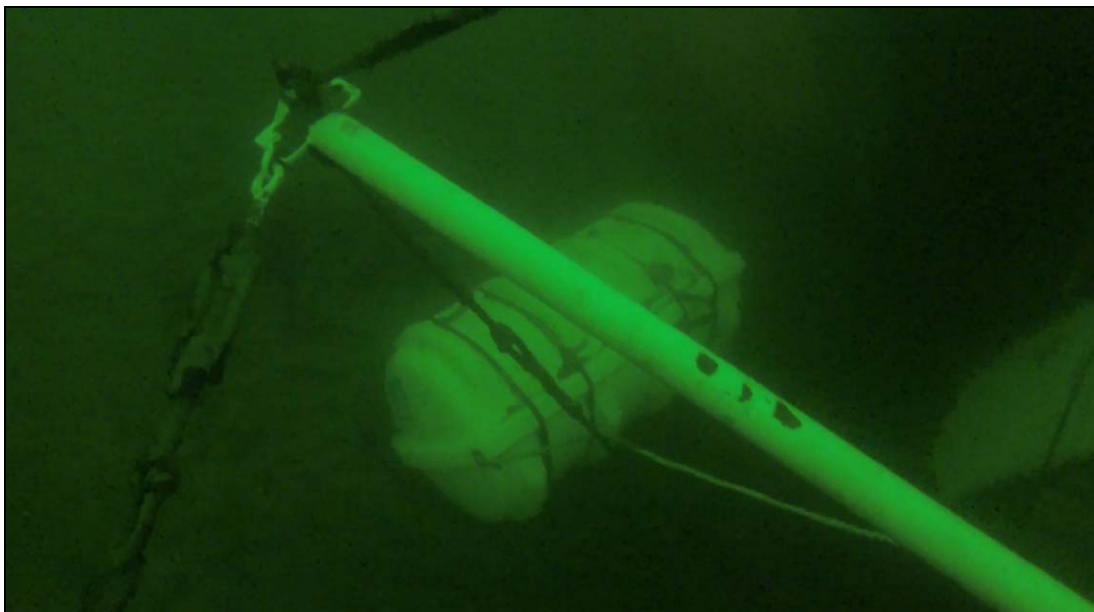


**Figure 11: Determination of individual masses when the fishing vessel was dismantled (above the wheelhouse) in September 2016**



**Figure 12: Special scale and device for wirelessly recording measurements**

Other focal points of the BSU's investigation were aimed at clarifying why the liferaft on board the fishing vessel did not float up to the surface after the vessel foundered and why the emergency position-indicating radio beacon (EPIRB) installed on the fishing vessel, which was designed to transmit an automatic distress signal after the vessel foundered, also failed.



**Figure 13: Non-surfaced liferaft on the FV CONDOR<sup>11</sup>**

Both the liferaft and the EPIRB satisfied internationally binding specifications and had undergone routine servicing by authorised service partners of the respective manufacturer in due form at the instigation of the fishing vessel's skipper prior to the accident.

<sup>11</sup> Source: Image taken from police diver video recording (11 February 2016).





Figure 14: FV CONDOR's EPIRB<sup>12</sup>

The BSU contacted the manufacturer of each safety device and was assisted by them in searching for the cause of the malfunction.

In addition to the above technical aspects, another focal point of the BSU's investigative work was to employ all relevant sources of information in reconstructing the course of the fishing vessel's voyage before she foundered. Apart from the radar recordings of VTS Travemünde, no other objective sources of information were available to begin with, as on the day of the accident the AIS system, which was required and indeed carried on board the fishing vessel, had not been switched on for reasons that could not be explained subsequently.

The BSU attempted to read stored tracking data from the navigation equipment installed on the bridge with the support of the respective manufacturer. It transpired that only one of the three devices secured is equipped with an internal track memory (battery powered), namely the FURUNO GP-32 GPS receiver. The BSU asked the manufacturer to assist it with reading the data. It was established in the process that the memory's battery had completely discharged during the four weeks in which the fishing vessel was on the seabed. Consequently, the efforts to read data from the battery-powered memory failed.

---

<sup>12</sup> Note: The EPIRB first floated to the surface of the water during the salvage operation and was then secured by the salvage company.

The BSU had already requested administrative assistance shortly after the accident from the Fisheries Inspectorate at the Federal Office for Agriculture and Food (BLE) for the purpose of obtaining technical recordings of the course taken by the CONDOR. Based upon European and national legal requirements, the BLE uses a special satellite-based system to ensure that German-flagged fishing vessels comply with fishing legislation. To this end, a special antenna is installed on board each vessel, which automatically (i.e. at fixed intervals and/or due to certain events) transmits GPS-based encoded position data. These data are recorded by the BLE and were made available to the BSU in respect of the FV CONDOR. Since the recordings are generally only made at sparse intervals of possibly less than once an hour as per the design, the BSU made attempts to read data stored at shorter intervals from the internal memory of the antenna, which remained intact during the accident. The service company that works for the BLE provided technical assistance with this.

In order to find out about the technological processes involved in fishing on the FV CONDOR or similar fishing vessels, the BSU planned to speak with fishermen from the Fehmarn fishermen's cooperative. Unfortunately, the fishermen there were not prepared to provide the BSU's investigation team with information on and insights into their daily work. Nevertheless, it was possible to obtain answers to questions about the practical procedures on board fishing vessels during a detailed discussion with an expert and experienced teacher from the Rendsburg Fishing School, which was also attended by the BSU's two technical experts.

To clarify the question of whether and to what extent the weather conditions had an impact on the course of the accident, the BSU requested a weather report from Germany's National Meteorological Service (DWD).

In the interest of a comprehensive analysis of all available sources of information, the BSU sighted the ship's files of the FV CONDOR kept by the Ship Safety Division (BG Verkehr) and the BSH in the course of the investigation. The findings of WSP Kiel were also referred to. Furthermore, the BSU was also able to view the expert's opinion prepared on behalf of the Versicherungskasse für Fischereifahrzeuge an der Lübecker Bucht (insurance fund for fishing vessels in Lübeck Bay).

The above sources of information and investigative steps enabled the BSU to clarify the course and causes of the accident, as well as the underlying circumstances to a large extent and to draw the necessary conclusions.

### **3.3.2 FV CONDOR (basic information)**

#### **3.3.2.1 General information**

The FV CONDOR was a fishing vessel with a wooden hull, steel wheelhouse and an A-mast mounted on the fore section. A large net-winding winch with two net drums were situated on the starboard side of the foredeck immediately in front of the wheelhouse.

The fishing vessel was built in 1943 at a shipyard in the former West Pomerania and then used continuously by various owners for coastal fishing, mainly in the Baltic Sea. To this end, she was most recently intended and equipped for fishing with trawl nets.

Various conversions and modernisation work was carried out on board the fishing vessel over the years. The main engine was renewed and larger winches mounted on the main deck several times, for example. The fishing vessel's navigation, radio and safety equipment was also adapted in line with technical advancement and changing carriage requirements.

From the files of the BSH and the Ship Safety Division (BG Verkehr (formerly the Marine Insurance and Safety Association – See-BG)) viewed by the BSU, it is evident that for the most part the various owners had the CONDOR inspected regularly and in due form across the decades. The owners rectified any defects found in the process. Accordingly, the fishing vessel had all the necessary certificates and permits at the time of the accident, in particular, a safety certificate for fishing vessels valid until 18 August 2018.

The BSU noted during the first survey of the fishing vessel after she was put ashore at Warnemünde that despite her advanced years and the fact that she had been on the seabed for some four weeks in the meantime, her maintenance status was astonishingly good.

### **3.3.2.2 GRP coating**

The hull of the fishing vessel was presumably given a GRP coating in 1997. In 2001, the then See-BG notified the owner of the fishing vessel in writing that such a coating was reportedly not permissible. This reportedly may separate from the surface due to moisture in the wood and possibly cause the shell plating to rot undetected. There would be a risk of cracking and sudden water ingress. The owner was therefore instructed to remove the GRP coating by the next survey. As an alternative, it was suggested that drill samples be taken at defined points when the vessel was next in dry dock to check the condition of the hull. The owner made use of the latter option during the regular inspections. However, anomalies were never detected.

After the fishing vessel was salvaged, the hull exhibited large cracks at several points in the GRP coating (see **Fig. 15 f.**). Consultations with the salvage company revealed that these cracks were an inevitable consequence of the stresses on the hull during the lifting process. It was also found that the fishing vessel's wooden hull under the GRP coating did not exhibit any damage caused by decay. The initial suspicion that there may have been a connection between the CONDOR's GRP coating, rated inadmissible and/or problematic by the See-BG, and the foundering of the vessel was not confirmed.



**Figure 15: Cracks in the GRP coating**



**Figure 16: Cracks in the GRP coating (close-up)**

### **3.3.2.3 Stability documents**

In a survey report of See-BG<sup>13</sup> prepared in 1998, it was found that there was no proof of stability on board for the fishing vessel. This did not have any consequences to

---

<sup>13</sup> Note: In the course of the trade association restructuring measures that started in 2010, See-BG merged with the Ship Safety Division (BG Verkehr). Its full name has been the German Social Accident Insurance Institution for Commercial Transport, Postal Logistics and Telecommunication since 1 January 2016. As far as the report deals with the activities of the trade association prior to 2010, the original name (See-BG) is used hereinafter.

begin with. The absence of proof of stability was also noted but not challenged by See-BG during surveys carried out in 2001 and 2003.

In August 2005, See-BG instructed the owner of the fishing vessel in writing to arrange for a combined roll period and inclining test in the presence of a technical supervisor to determine the stability values. This was carried out on 5 October 2005 in the port of Heiligenhafen and evaluated shortly afterwards by Germanischer Lloyd (GL).

GL subsequently stated in a letter dated 28 November 2005 that the stability of the fishing vessel was reportedly sufficient for fishing vessels with simple fishing gear. A letter from See-BG to the fishing vessel's owner dated 1 August 2006, which expanded upon the above finding, also informed the latter that beam trawling may only be carried out if either stability-enhancing measures are carried out or if an automatic device for the rapid release of snagged fishing gear is installed on the fishing vessel. Since this type of fishing was not carried out in the subsequent period, a corresponding retrofit was not necessary.

During the last survey (on 25 August 2014) of the fishing vessel before she foundered, the owner of the fishing vessel was informed, inter alia, that in accordance with the Guideline according to Article 6(1)(6) of the Ship Safety Ordinance on safety regime for fishing vessels of less than 24 m in length of 2009 (Guideline for fishing vessels < 24 m in length), proof of stability must be provided every ten years. The owner was advised that the last roll period and inclining test took place on 5 October 2005 and instructed to have a complete inclining test carried out by an authorised engineering firm in the presence of a nautical surveyor from the Ship Safety Division (BG Verkehr) at the latest before the fishing vessel was next put into dry dock in 2016. This test was no longer carried out due to the accident in February 2016.<sup>14</sup>

#### **3.3.2.4 Life saving appliances and safety equipment**

The CONDOR was carrying rescue and safety equipment according to the applicable regulations when she foundered. Accordingly, an inflatable liferaft for six people, two lifejackets, two lifebuoys, two immersion suits and a 406 MHz satellite EPIRB were on board.<sup>15</sup> The equipment for visual distress signals also complied with legal requirements.

#### **3.3.2.5 Scrapping the fishing vessel**

Although the hull and superstructure had survived the foundering and salvage of the vessel largely unscathed, no serious consideration was given to repairing the more than 70-year-old wooden fishing vessel for economic reasons.

---

<sup>14</sup> Note: For the technical and legal details of the aspect of stability, see the comments below in sections 3.3.15, 4.4.2 and 5.1 of this investigation report.

<sup>15</sup> Note: See the comments on the examination of the liferaft and EPIRB below in sections 3.3.11, 3.3.12, 4.2, 4.3, 5.2, and 5.3 of this investigation report.

Instead, the CONDOR was completely dismantled on the grounds of the buoy yard on behalf of WSA Stralsund and her parts disposed of properly upon completion of the investigation in September 2016.



**Figure 17: Scrapping the FV CONDOR at the buoy yard (final phase)**

### **3.3.3 Fishing vessel dive report**

In the report drawn up by the ship's command of the survey, wreck search and research vessel DENEK after the dive on the wreck of the CONDOR, the condition of the fishing vessel is described as follows:

*"The fishing vessel is lying on her starboard side. The rudder and screw are clear. The rudder is about 25° starboard. No damage could be identified on the exposed areas (fore section, keel, stern, port side and part of the underwater hull on the starboard side). The wheelhouse windows are intact. The wooden bridge bulkhead on the port side was closed. The divers were not able to access the wheelhouse with equipment because of the narrow passage. The liferaft is floating about 1 m above the aft edge of the wheelhouse. Released by the hydrostatic release unit, the release cord is snagged in the shrouds of the aft mast. [...] The fish chute that used to hang on the port side was found about 25 m south of the wreck. The round antenna on the aft mast is bent to the side. The distress beacon, which is most likely attached to the wheelhouse on the starboard side, could not be found. If the EPIRB is still in its mount, then it is not accessible due to the position of the wreck. No fluids escaped while we were at the wreck position or during the dive. Two videos were recorded, one by the divers and another using the remotely operated vehicle.*

### 3.3.4 Report of the salvage company

The salvage company commissioned by the BSU (Baltic Taucherei- und Bergungsbetrieb Rostock GmbH) submitted a written report and photographic and video documentation shortly after the wreck was raised successfully. A summary of the report, which has been edited moderately and supplemented by additional photographs of the BSU, follows:

#### *" [...] Execution*

03/03/2016 *The floating crane and MIRA A arrive in the port of Rostock*  
04/03/2016 *Equipment with diving and salvage gear*  
05/03/2016 *Standby – bad weather, 2100 cast off and head for location*  
06/03/2016 *Assemble equipment, investigate wreck, preparatory work,  
first attempt at lifting*  
07/03/2016 *Additional dives to position the lifting gear,  
1830 wreck lifted and stowed on the MIRA A*  
08/03/2016 *0400 wreck lashed to MIRA A, depart for Rostock,  
1130 wreck set down at the buoy yard in Warnemünde,  
handover to client, 1530 demobilisation of equipment*

#### Notes on the salvage

*The vessel's situation corresponded to the information provided in the DENEb's investigation report. The two openings main deck starboard side aft level with superstructure [sic] (diameter of each about 11 cm) were not closed. A cover was found not far from the bulwark and handed over to the client. The thread was so worn that it was not possible to establish a force-locked connection with the opening. The salvager provisionally sealed the two holes with bungs.*

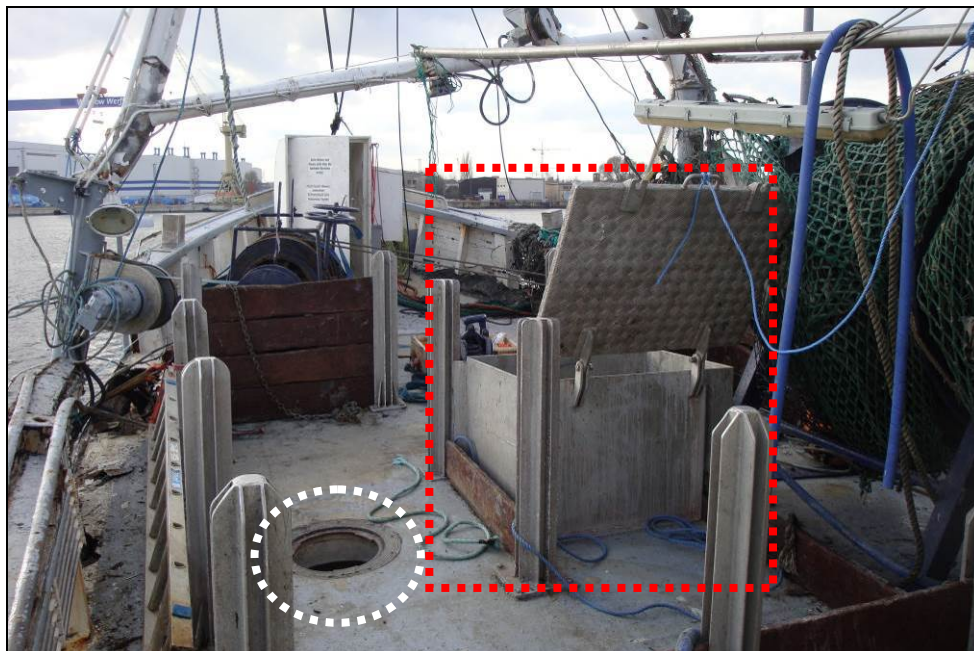


**Figure 18: Opening 1 in the main deck**



**Figure 19: Opening 2 in the main deck (the associated cover is at the top right)**

*Moreover, the hold for storing caught fish was found to be completely empty. The main hatch cover to the hold (see red marking in **Fig. 20**) was closed but not secured. The adjacent opening on the port side (diameter about 50 cm, see white markings in **Fig. 20**) was not closed, nor was a cover present.*



**Figure 20: Access openings to the hold<sup>16</sup>**

*The door to the engine room was open; the doors to the wheelhouse (port and starboard) were closed; all the windows were intact and closed. The door to the companionway on the fore section was also open. There was a hole of about 1 m in diameter in the partition wall between the companionway to the engine room and skipper's berth aft of the bridge (see **Fig. 21**).*

<sup>16</sup> Note: The photograph was taken after the fishing vessel arrived in Warnemünde.





**Figure 21: Hole in the partition wall between the companionway and skipper's berth**

*The rudder blade did not change its position during the salvage operation and was found according to the information in the DENEb's file (see Fig. 22).*



**Figure 22: Position of the rudder blade (unchanged during the salvage operation)**

*The liferaft was found lying in the area of the aft superstructure. It was closed and still attached to the release cord.<sup>17</sup> The EPIRB floated to the surface when the wreck was righted above ground. It did not transmit a signal after floating to the surface. The EPIRB was recovered and handed over to the BSU.*

---

<sup>17</sup> Note by the BSU: The divers temporarily attached the liferaft to the fishing vessel's mast during the salvage operation.

*After the fishing vessel had been drained, her position in the water was normal with a slight heel to starboard. No new water ingress was detected.*

*Two nets containing cod were found (green large-meshed). The two nets were full of fish located on the starboard side level with the net-winding winch and partly lying under the bulwark. The nets were still connected to the mast.<sup>18</sup> [...] Additional empty nets were located on the starboard side in the fore section (level with the A-mast) and on the port side of the prow.*

*Due to the condition of the fishing vessel, which had been on the seabed for four weeks, and unavoidable mechanical stresses while preparing for and executing the lift, the following damage occurred during the salvage operation:*

- 1. damage to the bulwark on the starboard side of the fore section (first stop position of the lifting slings);*
- 2. A-mast and bulwark on port side of fore section torn out during the lift;*
- 3. port side of fore section (second stop position of the lifting slings);*
- 4. cracks in the GRP coating on the starboard side of the main deck between the A-mast and large net-winding winch;*
- 5. cracks in the GRP coating on the starboard side midships, bilge strake.*

[...]"

### **3.3.5 Visual inspection of the wreck after she arrived in Warnemünde**

After the fishing vessel had been secured on the pier by bracing made by the salvage company using wooden beams (see **Fig. 9** on p. 22 of this report), an initial survey was carried out by the BSU's investigation team and the experts commissioned with the stability assessment.

It was striking that the rudder was set to (hard to?) starboard and starboard max. (about 45°) was displayed on the rudder position indicator (see **Fig. 23**). The engine lever on the bridge operator stand indicated slow ahead (see **Fig. 24**).



**Figure 23: Rudder position indicator (wheelhouse on the FV CONDOR)**

---

<sup>18</sup> Note by the BSU: It transpired in the course of the investigation that rather than two nets filled with fish, there was only one net in which the last haul before the accident had evidently gathered in two different parts at the time of the salvage operation.



**Figure 24: Control lever (wheelhouse on the FV CONDOR)**

The fishing vessel's screw could be rotated freely and exhibited no damage. (The free rotation seemed illogical at first because a decoupled engine and the rate of speed slow ahead did not seem to be compatible. However, an inquiry with the expert commissioned with assessing the engine during the further course of the investigation revealed that the hydraulic coupling of the engine is designed (i.e. intended) to trigger the idling of the drive shaft as soon as the engine – for whatever reason – switches off.)

The first visual inspection of the fishing vessel (from the pier and directly on board) did not yield any particular indicators or evidence as to the cause of the accident. The BSU's investigation team dismantled the three navigation devices on the bridge as a precautionary measure. Other seizures were not necessary for the time being. Although various written documents were found, some of which were even still in a legible condition, a deck log book could not be located despite an extensive search of the wheelhouse, which was destroyed when the vessel foundered.

It was striking that the fishing vessel's external condition – i.e. in terms of paint and general maintenance status – was sound and had not deteriorated significantly as a result of spending one month at the bottom of the Baltic Sea. According to the salvage company's report, the sole cause of damage to the fishing vessel's structure was the mechanical forces and unavoidable effects while lifting and subsequently setting her down on the multipurpose vessel.

Some of the loose boards apparently used to separate the main deck into individual compartments (hurdles) were still in the fore section of the fishing vessel. To this end, the boards are pushed into vertical guides.

The result is individual compartments open at the top into which the fish are poured out of the net on deck, slaughtered there, rinsed and later stowed in crates (each in a separate compartment). There was no trace of the actual crates. The fish hold below the main deck was empty and looked clean and unused.

The fishing vessel had two large net drums in front of the wheelhouse on the starboard side. The forward one in the direction of travel was disengaged and the net reeled in completely. (According to the situation at hand, this drum was not used on the day of the accident.) The rear drum was engaged. Apart from a relatively short final end, it initially seemed as if the net had been completely wound on to this, too.

However, it was found on closer inspection during the second survey on 15 March 2016 that the net's codend had only been opened, emptied and then wrapped around the winch for reasons of safety during the salvage operation. In agreement with the salvage company's report, during the second survey on 15 March 2016 it was possible to reconstruct unequivocally that the net's codend had been filled with fish when the fishing vessel foundered but in all likelihood had still not been hoisted on deck and set down there.

### **3.3.6 Weather conditions (DWD report)<sup>19</sup>**

A summary of the DWD's official report on the weather conditions in the area and at the time of the accident follows:

#### "Mean wind (at a height of 10 m above the water surface)/gusts

*Due to the stable air stratification, the flow was not turbulent. The influence of surface friction closer to the water's surface thus led to a continuous and steady decline in wind.*

*At 10 m above sea level, southern mean winds of force 5 Bft prevailed throughout the above period (16-20 kts from 190°). Given the stable air stratification, it is highly unlikely that there were any gusts of more than two wind speeds above the mean wind close to ground level.*

#### Significant sea state

*Due to the limited wind fetch over Lübeck Bay and in the Fehmarn Belt, only a short-wave wind sea of about 1 m in height was able to develop. There was no significant swell.*

#### Weather and visibility

*Temperature inversions, as in this case, generally lead to the lower air layer separating from the upper air layers. They prevent the humid air below an inversion from dispersing. It was mostly overcast over the entire period. A few drops of rain fell from dense stratus clouds early on but it was dry subsequently. Good visibility of more than 10 km prevailed for most of the period. At 2-5 km, visibility was poor early on.*

---

<sup>19</sup> Source: Official report by Germany's National Meteorological Service (DWD) of 1 March 2016 on the weather and sea conditions in the western part of the Baltic Sea east of Fehmarn (54°25.5'N; 011°24.1'E) between 0600 UTC and 1400 UTC on 6 February 2016.

### Temperature

Water temperatures stood at 3-4°C and air temperatures varied at 5-7°C at 2 m above sea level in the mild southerly inflow.

### Current

The mean current velocities fluctuated at 0.3-0.8 kts from south to south-east in the layer between 0 and 5 m water depth. The current velocity decreased significantly as the day progressed.

The DWD had not issued any official wind warnings for the period and region of relevance to the accident.

### **3.3.7 Professional experience of the two crew members**

The skipper was 52 years of age at the time of the accident and had many years of professional experience in coastal fishing. He acquired the FV CONDOR in 1997 and has since been the skipper of the fishing vessel.

The second crew member was 45 years of age at the time of the accident and has also worked in coastal fishing for many years.

### **3.3.8 Workload**

The CONDOR set sail for the fishing grounds at 0647 on the day of the accident. The two crew members had been working on board for about five hours when the accident happened. They fished intensively upon reaching the fishing grounds, took a large quantity of fish on board, and started to process them immediately in the usual manner. Despite the high degree of physical stress this inevitably entails, there is no evidence to suggest that physical exertion or fatigue may have triggered the accident. Both crew members were fit for service at sea without any constraints and had been familiar with the hard work on board the fishing vessel for years.

### **3.3.9 Alcohol**

Neither the skipper of the fishing vessel nor the deckhand were under the influence of alcohol at the time of the accident.

### **3.3.10 Autopsy of the victims and cause of death**

An autopsy was carried out on the two victims on 11 February 2016 at the Institute of Forensic Medicine, Schleswig-Holstein University Clinic in Lübeck.<sup>20</sup> The diagnostic findings were indicative of drowning in fresh or Baltic Sea water in each case. The skipper of the fishing vessel was also found to have suffered trauma caused by a blunt object in the form of skin abrasions and haematomas on his forehead. These could have been caused by a fall during the accident or in the course of the recovery. Only the deckhand was found to be displaying symptoms of hypothermia.

---

<sup>20</sup> Source: Autopsy reports HL\_S038-16 and HL\_S037-16 (L2448-15) of the Institute of Forensic Medicine (Schleswig-Holstein University Clinic) of 11 February 2016.

### 3.3.11 EPIRB

#### 3.3.11.1 Investigation of the BSU

The FV CONDOR was equipped with an EPIRB<sup>21</sup> for marking an emergency position in accordance with national and international regulations. The waterproof and buoyant EPIRB can be activated manually on board. It also releases from its mount automatically, i.e. by means of a hydrostatic release unit, at the latest when the vessel founders at a depth of 4 m, then floats to the surface and begins to transmit an alarm signal continuously on a standardised distress frequency. In the case of the type of EPIRB used on the FV CONDOR, this signal also includes the current GPS position of the beacon and information about the identity of the associated vessel. The distress signal is received by satellites of the COSPAS/SARSAT system and transmitted to a ground station, from where – depending on its geographical starting position – it is received by one or several MRCCs (maritime rescue co-ordination centre(s)), which are spread across the globe. The MRCC evaluates the signal and if a false alarm can be ruled out immediately initiates any search and rescue measures necessary.

The ship's files of the German Shipping Administration indicate that the EPIRB (SAILOR SGE 406 II Satellite GPS) on board the FV CONDOR was last inspected by an authorised service company in October 2015. The beacon itself, the associated hydrostatic release unit and the mount were in good condition at that time. The EPIRB was mounted aft of the deckhouse on the starboard side of the fishing vessel (see red marking below in **Fig. 25**).



**Figure 25: FV CONDOR – mounting position of the EPIRB**

<sup>21</sup> EPIRB: **E**mergency **p**osition-**i**ndicating **r**adio **b**eacon.

Ref.: 44/16

MRCC Bremen advised that it had not received an EPIRB signal from the FV CONDOR on the day of the accident or afterwards in response to an inquiry of the BSU made after the accident. Since the fishing vessel was lying on her starboard side on the seabed, it was not possible to conclude from the divers' video recordings whether the EPIRB had detached itself from the mount (as per its design) after the fishing vessel foundered.

The salvage company detected the EPIRB, which exhibited no damage, at the scene of the accident on the surface of the water during the salvage operation and handed it over to the BSU after the fishing vessel arrived in Hohe Düne, Rostock.



**Figure 26: FV CONDOR'S EPIRB**



**Figure 27: FV CONDOR immediately after salvage (empty EPIRB mount visible)**



**Figure 28: Open EPIRB mount (starboard side of fishing vessel – wheelhouse)**

It was not possible to clarify why the EPIRB, which apparently only floated to the surface in direct connection with the fishing vessel's salvage operation, failed to reach the surface of the water on the day of the accident. That the hydrostatic release unit failed on the day of the accident and was only activated 'coincidentally' by mechanical forces acting on the fishing vessel during the salvage process cannot be ruled out. Since the actual hydrostatic release unit could not be found, investigating this hypothesis further was not possible.



**Figure 29: Example of a hydrostatic release unit<sup>22</sup>**

<sup>22</sup> The module belonging to the FV CONDOR's EPIRB could not be found.



However, the BSU believe that it is possible and more likely that the EPIRB released properly from the mount when the fishing vessel foundered but was subsequently caught in the superstructure, a mast or other parts of the fishing vessel due to a chain of unfavourable factors and thus prevented from reaching the water surface.

### 3.3.11.2 Investigation by the manufacturer

Since the BSU's assessment of the EPIRB and its mount, which also exhibited no damage whatsoever and appeared to be in proper working order (see **Fig. 28** above), did not permit any conclusions as to the cause of the EPIRB's failure, the manufacturer of the system, the Portsmouth-based (UK) McMurdo Group, was contacted in May 2016 and asked to carry out a supplemental assessment of the EPIRB.

The company was very cooperative and inspected the radio beacon and the mount in its own laboratory on receipt. The BSU received the manufacturer's assessment report in October 2016 following a corresponding request.

The report essentially arrives at the summarised results below (see also the two extracts from the report on the following pages)<sup>23</sup>:

- (1) watertight integrity and pressure test carried out and passed;
- (2) internal battery's electrical voltage measured and stands at 5.5 V (more than 9 V required for proper functioning);
- (3) test battery installed in the EPIRB, test routine started and completed successfully;
- (4) mount inspected and no functional or mechanical defects evident;
- (5) EPIRB disassembled and no signs of water ingress;
- (6) the lanyard<sup>24</sup> belonging to the EPIRB (see photograph below in **Fig. 31**) was rolled up and wrapped in plastic film, meaning it could not have caught on the fishing vessel.

Quoted verbatim, the report reads:

*"We can state, that there was a very high probability that the EPIRB auto-released, auto-activated and transmitted under water until the battery lost power. [...] From this, there may have been an issue with the EPIRB catching in nets or deck equipment."*

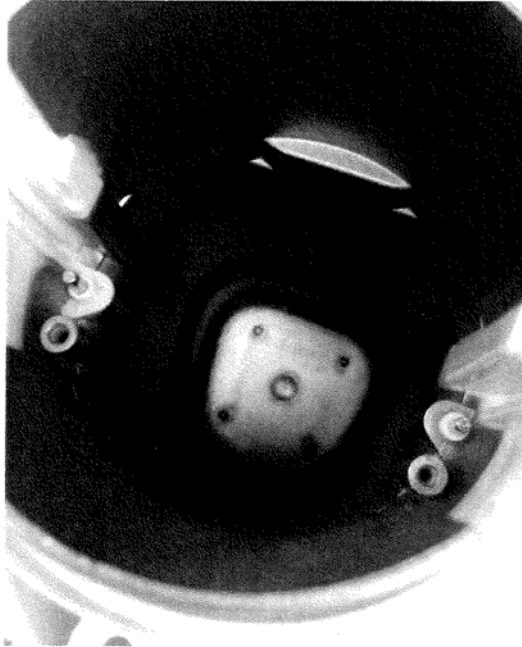
---

<sup>23</sup> Source: McMurdo QA report OBS13 – Sailor SGE 406 ii GPS EPIRB\_10-06-2016\_11-03-30.pdf.

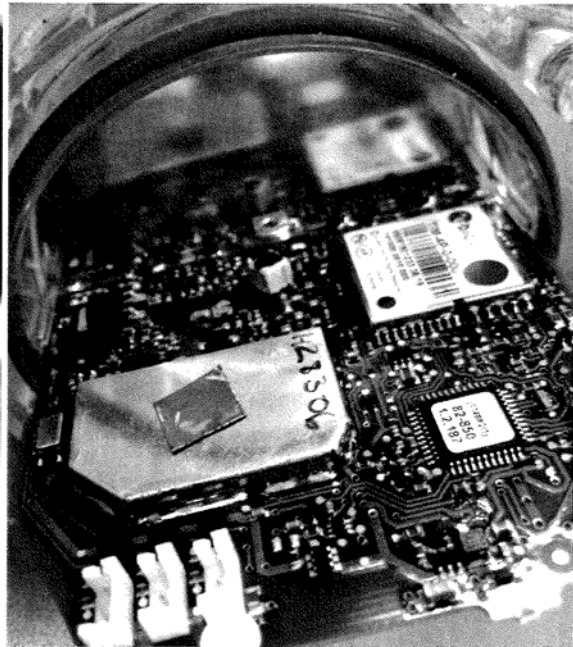
<sup>24</sup> Note by the BSU: The lanyard is used to attach the EPIRB to a lifeboat or liferaft in instances where the crew is ordered to abandon ship.

Having conducted the internal investigation from both the returned components, the supplier report and photographs, we are unable to detect any issue that may cause concern.

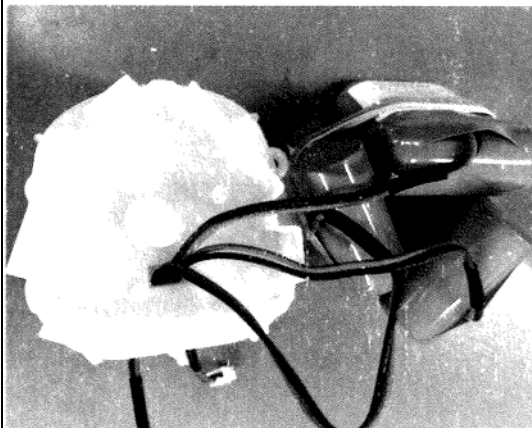
Our investigation confirmed that there was no evidence of leaking even after sitting on the bottom of the sea bed the results of this well exceeding the design criteria (depth and length of time).



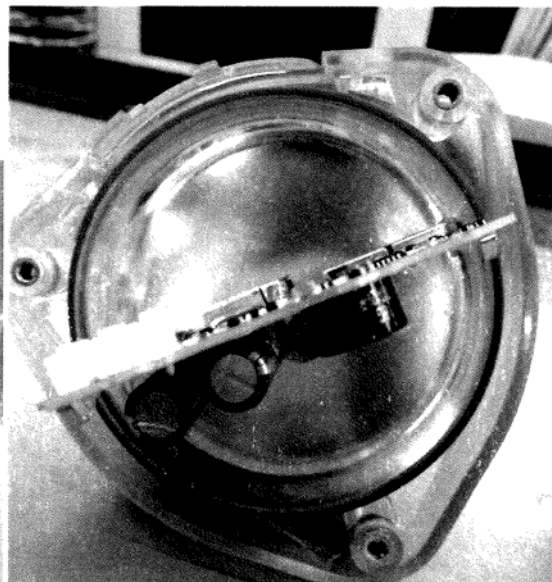
*Base of unit was dry.*



*No signs of corrosion on PCB*



*Battery housing mould dry*



*O-ring seal intact and good condition – no evidence of damage*

NVRAM data indicates that an activation was made and confirming that the activation runtime vastly exceeded the design criteria. We can state that there was a very high probability that the EPIRB auto-released, auto-activated and transmitted under water until the battery lost power.

**Figure 30: Extract 1 from the EPIRB manufacturer's assessment report**

Program

Press TEST

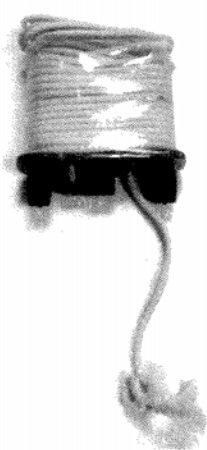
**Beacon Selftest Data**

```

Run Time : 119.10.18
406MHz Power : OK 1023
121MHz Power : OK 967
Long GPS Selftests Remain : 11
406MHz PLL : OK locked
406 Output detected : OK detected
121.5 Output detected : OK detected
E2PROM Checksum : OK good
Battery life indicator : WARN exceeds limit
System settings : OK
Morse settings : not programmed or tested
Battery settings : OK
GPS settings : not programmed or tested
GPS test settings : not programmed or tested
Power detector settings : not programmed or tested
    
```

The long activation runtime is more than double of what you would expect at 20c air temperature @ 119H. This duration could be attributed to the unit being held in a relatively warm sea water temperature, at least for the initial 4 days while under water. From this, there may have been an issue with the EPIRB catching in nets or deck equipment.

The lanyard of the EPIRB has been discounted of causing the beacon to remain under water as this was found to be still wound and wrapped in its plastic sleeve so couldn't have caused the EPIRB to become tangled and prevent it from reaching the surface.



**Figure 31: Extract 2 from the EPIRB manufacturer's assessment report**

The manufacturer answered the BSU's question as to what McMurdo's specifications for the mounting position of the EPIRB on board a vessel are as follows:

2 questions have been asked and are as follows:

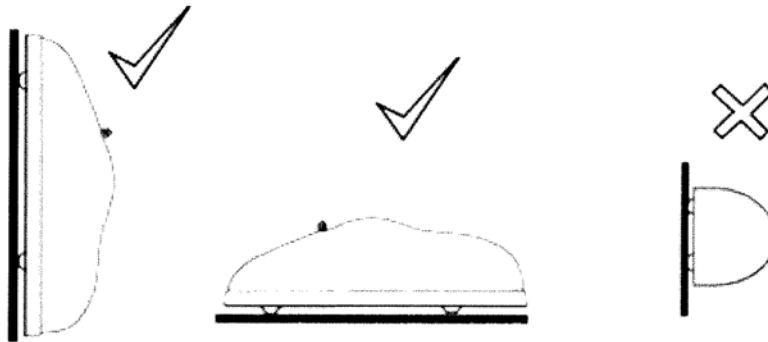
1. Are there any manufacturer-specific requirements as to where on the ship the EPIRB is to be assembled? If so, which and where are they specified?
2. Do you consider it possible for the support (mount) of the EPIRB not being able to open after the foundering of the fishing vessel due to the, in this case, unfavourable mounting position at the starboard side of the vessel?

To answer:

1.

#### Category 1 automatic release installation

The enclosure should be mounted upright against a vertical bulkhead. Alternately, it may be mounted horizontally on a flat surface, such as a cabin roof. No other orientations are recommended.



It is critical to locate the enclosure in a position where the released EPIRB will not get trapped by overhangs, rigging, antennas etc, should the vessel ever sink. An expanse of flat surface is required to allow the enclosure lid to eject.

- Mount it where it can easily be accessed without use of a ladder
- Mount it close to the vessel's navigation position
- Consider ease of access in an emergency

#### AVOID:

- Positions with insufficient space for clean lid ejection and easy maintenance.
- Positions within 1m (3') of any compass equipment.
- Mounting within 2m (6') of any Radar antenna.
- Direct impact from waves.
- Locations where damage is possible when operating other equipment.
- Exhaust fumes, chemical and oil sources and areas of high vibration.
- Positions where the EPIRB could become trapped in a box section should the vessel become inverted.

#### Mounting procedure

Locate enclosure base against a flat surface using the 4 fixing points. The base plate of the enclosure can be used as a drilling guide

1. Pull out the R-shaped clip and remove the enclosure lid. Note how the EPIRB fits then remove it to somewhere dry (its sea switch is now armed).
2. Offer the base plate into the chosen position and mark through the mounting holes.
3. The enclosure is supplied with x4 25mm (1") stainless steel wood screw fixings. 6mm (1/4") nuts and bolts can also be used (not supplied).

**Figure 32: Extract 3 from the EPIRB manufacturer's assessment report**

This information is largely identical to the content of the installation instructions in the user manual for the SAILOR SE 406 II Satellite EPIRB and SAILOR SGE 406 II Satellite GPS EPIRB, which the manufacturer has published on the Internet.

With regard to the photographs of the EPIRB's mounting position on board the FV CONDOR sent by the BSU to the manufacturer, the manufacturer confirms in its assessment report that this met its own specifications.

### 3.3.12 Liferaft

#### 3.3.12.1 General preliminary remarks and initial findings

The FV CONDOR was equipped with an inflatable liferaft in accordance with national and international regulations. This liferaft's type designation is LR06-SOLAS-B. It is designed for six people and made by the German manufacturer DEUTSCHE SCHLAUCHBOOT (DSB) in Eschershausen, which belongs to the British Survitec Group. The model (designed for six to eight people) meets all internationally prescribed requirements and is approved for use in commercial shipping.

As is common for rescue equipment of this type regardless of manufacturer, the liferaft is tightly packed in a barrel-shaped container consisting of two hard shells. This container was stored on the side of the CONDOR on the upper edge of the deckhouse's port side in a specially designed mount (see **Fig. 33**).



**Figure 33: Position of the liferaft on board the FV CONDOR**

The crew can actively deploy the liferaft into the water in emergencies by opening or tilting the mount. Regardless of the above, the mount opens automatically by means of a hydrostatic release unit at the latest when the vessel founders at a depth of more than 4 m. The container's inherent buoyancy then propels it to the surface of the water.



**Figure 34: Hydrostatic release unit belonging to the FV CONDOR's liferaft**

The container of the CONDOR's liferaft was connected to the fishing vessel by a combined painter/release cord in accordance with requirements (see red marking in **Fig. 35 f.** below). This cord has two functions. Firstly, it ensures the liferaft's container does not drift away from the distressed vessel due to wind and swell after it enters the water. A weak link (see red marking in **Fig. 35 f.** below) in the area of the connection between the liferaft and vessel ensures a foundering vessel does not drag the liferaft down with her. The second function of the painter/release cord is to trigger the inflation process by a sharp tug on the cord, which is completely out of the container. The pressure that builds up inside the container causes the two shells that form the housing to open and the liferaft is able to inflate.



**Figure 35: Liferaft's mount and painter/release cord**



**Figure 36: Close-up of painter/release cord connection with liferaft mount**

In summary, the liferaft is designed to activate automatically in the following manner:

- (1) at the latest when the foundering vessel has reached a water depth of 4 m, a hydrostatic release unit ensures the liferaft is released from the mount;
- (2) the liferaft's inherent buoyancy propels it to the surface of the water;
- (3) the combined painter/release cord ensures that the liferaft's container initially remains connected to the vessel;
- (4) when the entire length of the painter/release cord has been pulled out of the container, the inflation process of the liferaft is activated either by the tractive force of the foundering vessel or if the vessel is already on the bottom by a crew member pulling sharply on the painter/release cord;
- (5) a weak link in the painter/release cord prevents the foundering vessel from dragging the liferaft into the depths. This is triggered by resistance (buoyancy) to the tractive force of the foundering vessel caused by the inflating liferaft. As a result, the combined painter/release cord separates from the sinking vessel.

The documents sighted by the BSU after the accident indicate that the last routine service of the FV CONDOR's liferaft was in December 2015.

A liferaft could not be located on the surface of the water during the search and rescue activities after the fishing vessel foundered. Instead, it was found during the first dives on the wreck of the fishing vessel that the liferaft had detached from the mount and was floating in the water behind the aft edge of the deckhouse attached to the fishing vessel by the taut painter/release cord. (See **Fig. 37 f.** and especially the red marking in **Fig. 38**. The course of the line, which is barely visible in the murky water, is highlighted by a white dotted line in **Fig. 38** for better illustration.)



**Figure 37: Empty liferaft mount (extract from the DENEb's dive video – 12 February 2016)**



**Figure 38: Liferaft next to the wreck of the CONDOR with line connection to the fishing vessel (extract from the DENEb's dive video – 12 February 2016)**

### **3.3.12.2 Investigation of the BSU**

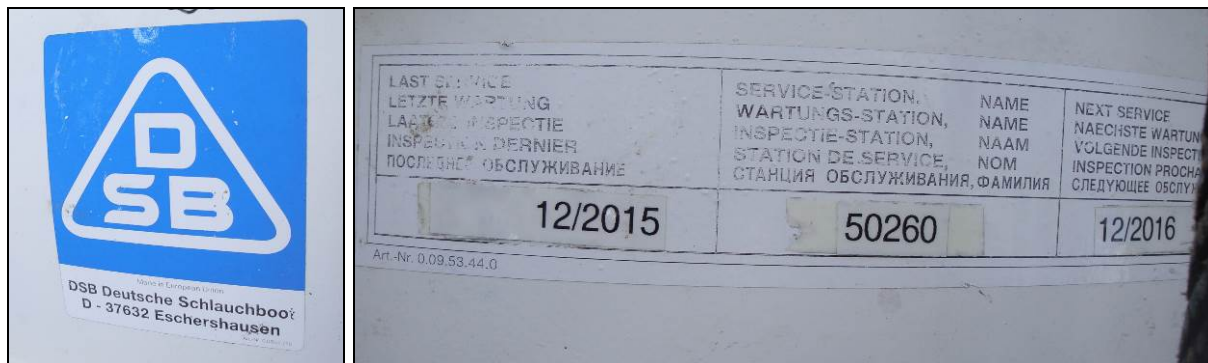
The BSU instructed the salvage company to carefully salvage the liferaft when lifting the fishing vessel. The company complied with this request and provisionally attached the liferaft to a mast on the roof of the wheelhouse before lifting the fishing vessel.





**Figure 39: FV CONDOR (arrival in Rostock; liferaft provisionally attached to the mast)**

The BSU first viewed the liferaft on the roof of the fishing vessel on 8 March 2016 after the fishing vessel was put ashore on the buoy yard pier in Hohe Düne, Rostock. The outside of the container did not exhibit any damage. Affixed to the surface of the container were references to the manufacturer of the liferaft, the last and the next service dates, and a number indicating the service station at which the liferaft was last serviced (see **Fig. 40**).



**Figure 40: Information about the manufacturer and service interval on the FV CONDOR's liferaft**

The combined painter/release cord protruded about 3.5 m from the inside of the closed container at the intended opening (see **Fig. 41**) but contrary to the specifications (tractive force of only 150 Nm) could not be pulled out further even with moderate force.



**Figure 41: Close-up of the liferaft's container (opening for the painter/release cord)**

It thus became clear that the liferaft's mount must have opened hydrostatically after the fishing vessel capsized. However, the liferaft was unable to reach the surface of the water through its inherent buoyancy, as it was obstructed by the painter/release cord not paying out smoothly.

A decision was made to open the liferaft in the presence of representatives of the manufacturer to examine the presumed functional problem more closely. In the meantime, the liferaft was stored safely in the buoy yard's service building.

The BSU contacted DSB by phone and email. DSB immediately and unconditionally showed great interest in the case and agreed to participate in the examination in Rostock scheduled for 23 March 2016.

Two investigators and the expert commissioned by the BSU to clarify stability issues, who also has specific expertise in the field of lifeboats/liferafts, attended the meeting for the BSU. The manufacturer, DSB, was represented by two experts from the engineering and sales divisions. The liferaft was examined in a workshop on the grounds of the buoy yard.



Figure 42: Liferaft before further examination<sup>25</sup>



Figure 43: Information about type approval, manufacturer and technical data on the liferaft's container

In a brief preliminary discussion, the manufacturer's representatives first answered basic questions about the operation of the type of liferaft in question. In addition, DSB also advised that the number of the station on the liferaft, which carried out the

<sup>25</sup> Note by the BSU: The grey adhesive tape visible in the figure was applied to the container only for transport purposes after the fishing vessel arrived in Rostock.

service in December 2015, belongs to an authorised service centre of the manufacturer in Denmark (Fredericia).

On the BSU's question as to how the routine servicing of a liferaft is carried out, the manufacturer's representatives provided the following information:

Each routine service involves removing the liferaft from the container, inflating it with an external compressed air source, and checking it for leaks and other signs of wear. The expiration date of items in the liferaft (provisions, signalling equipment) is checked and they are exchanged if necessary. The propellant gas level in the pressurised container is checked by weighing. The service is recorded on the liferaft (inside in the area of the liferaft's entrance).

According to DSB, employees of the service centres located around the world complete a special training programme before the service centre is approved. In addition, the manufacturer has produced extensive documentation<sup>26</sup> in English containing precise and highly detailed instructions (including various illustrations) on how the servicing steps are carried out.

The subsequent external assessment of the liferaft in the presence of DSB re-confirmed that the 36-m-long painter/release cord was obviously caught in the container. It could not be pulled out further (3.50 m) even with physical effort (see **Fig. 44 f.**), even though this should normally have been a very smooth process, as confirmed by DSB.



**Figure 44: Maximum possible extraction length of the painter/release cord**

---

<sup>26</sup> DSB, Eschershausen, Germany, Wartungshandbuch / Service Manual for LR07 SOLAS Style Liferafts Throw overboard & Davit Launch Types [sic] (hereinafter referred to as 'service manual').



**Figure 45: Painter/release cord's exit point from the container  
(cord cannot be pulled out with muscular force)**

To determine the reason for the aforementioned malfunction, the liferaft's container was carefully opened. The following then became clear:

On the last occasion that the liferaft was packed, i.e. during the last service in December 2015, the painter sachet (special sachet in which the painter/release cord is stored) and the remaining line section protruding from the sachet within the container were not properly stowed in the container. In addition, the excess cord remaining inside the container was too long.

It was established beyond doubt that the cord snagged because of the faulty manner in which the last cord section was made ready and, in particular, the painter sachet inside the container. The tensile loaded cord is designed to glide freely out of the opening in the container, thus enabling the liferaft's inherent buoyancy to propel it to the surface after its mount opens hydrostatically, but was undoubtedly obstructed because the service was evidently carried out improperly (cord not made ready properly within the container). Accordingly, the liferaft was unable to float to the surface of the water and inflate.

The below figures demonstrate that the special sachet with the painter/release cord inside the container was not stowed in the manner explicitly stipulated by the manufacturer's service manual when it was packed. The painter sachet and the cord's end leading out of the sachet toward the outside of the container were not in the immediate vicinity of the opening in the container housing, but rather on precisely the opposite long side of the container.

Ref.: 44/16

To illustrate the above, **Figs. 46 ff.** below show the position of the opening for the painter/release cord in the container housing marked in red and the position of the painter sacht in white.



**Figure 46: First photograph after removing the top half of the container**



**Figure 47: Liferaft tipped carefully out of the container**

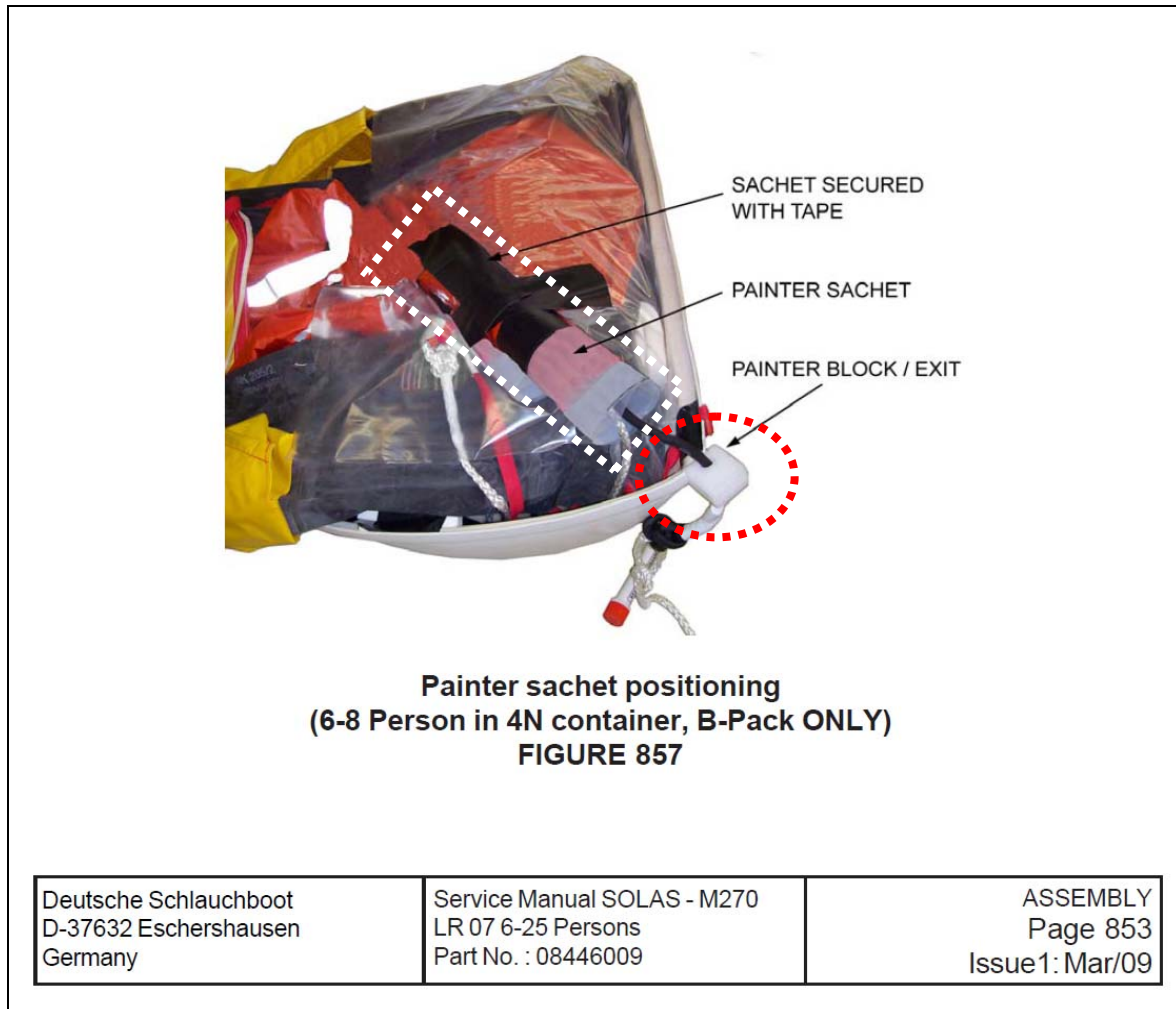


**Figure 48: Liferaft rotated 180° compared to Fig. 46**



**Figure 49: Intended position of the opening in the container compared to position of the painter satchel after removal of the liferaft's protective plastic covering**

The figure taken from the manufacturer's service manual showing the correct arrangement of the painter sacht inside the container (see **Fig. 50** below (or Figure 857 on page 853 of the service manual)) clearly shows that the actual stowage of the sacht in the liferaft involved in the accident did not comply with the manufacturer's instructions.



**Figure 50: Extract 1 from the service manual – manufacturer's instructions for positioning the painter sacht when packing the liferaft**

**Fig. 50** shows very clearly that the manufacturer has deliberately positioned the painter sacht within the container so as to allow the painter/release cord to escape from the container as quickly as possible. It stands to reason that this manner of stowing the painter sacht is essential to ensure the painter/release cord can escape from the tightly packed container smoothly and without catching.

In addition to illustrating this aspect with figures in the service manual, the manufacturer has also written very detailed instructions for this in the description of how to pack the liferaft (see the marked areas below in **Fig. 51** (or page 852 of the service manual)).



# DSB

# LR07

31. Wrap the remainder of polythene sheeting around the outside of the rolled liferaft, tucking the overlap into the bottom half of the container.
32. Remove the *painter sachet* from its temporary position on the side of the container.
33. Place the *painter sachet* along the back of the container, (FIGURE 856). Ensure the painter cord is in line with and close to the painter exit hole. Ensure the free run of painter from the sachet is not impeded.
 

**NOTE:** For 6-8 Person liferaft in a 4N container with B-Pack option ONLY, the painter sachet is positioned at an angle close to the painter exit, (FIGURE 857).
34. Ensure that the open end of the *painter sachet*, is as close as possible to the painter exit position on the container. Adjust the painter sachet extension so that the distance from it to the painter exit is between 100 - 150mm (4" - 6").
35. Ensure that there is sufficient distance between the material of the liferaft and the painter line so that they do not touch when painter line is pulled.
36. Secure the *painter sachet* in place, by taping it to the polythene sheet, (FIGURE 856).
37. Put the the rubber sheathed end of the *painter* line through the *painter retaining* block. Place the block into the cut-out in the container, (FIGURE 856).
38. Position the *Identification tube* ring at the edge of the container and tape it securely into place, (FIGURE 858).

**WARNING:** REMEMBER THE OPERATING MECHANISM IS ARMED. EXTREME CARE MUST BE TAKEN DURING ALL FOLLOWING ACTIONS.

39. Immediately before closing the *container* make sure that the *painter sachet* is:
  - (a) in line with the painter exit.
  - (b) attached to the liferaft with self adhesive tape.
40. Ensure that the open end of the *painter sachet*, is as close as possible to the painter exit position on the container. Adjust the painter sachet extension so that the distance from it to the painter exit is between 100 - 150mm (4-6").
41. Ensure that there is sufficient distance between the material of the liferaft and the painter line so that they do not touch when painter line is pulled.
42. Put the top half of the *container* on top of the folded liferaft, (FIGURE 858).

Deutsche Schlauchboot D-37632 Eschershausen Germany	Service Manual SOLAS - M270 LR 07 6-25 Persons Part No. : 08446009	CHAPTER 8 Page 852 Issue1: Mar/09
---	--	---

**Figure 51: Extract 2 from the service manual – manufacturer's instructions for positioning the painter sachet when packing the liferaft**

The instructions shown above clearly demonstrate how important it is that the opening of the painter sachet and free end of the painter/release cord leading outwards be as close as possible to the opening in the liferaft's container (see points 33 and 34 of the instruction above in **Fig. 51**). Point 35 of the instruction also stresses the need to ensure there is sufficient space between the liferaft material and

the cord. Points 39 to 41 once more emphasise the special duty of care when stowing away the painter sachet. The manufacturer re-emphasises here the importance of ensuring that the painter/release cord exiting the painter sachet can leave the liferaft's container by the shortest possible route and without obstruction before closing the container.

In reply to an enquiry from the BSU as to how the painter/release cord is put in the obviously very tightly and very purposefully packed sachet, the manufacturer's representatives explained that a special machine is used. This is the only way possible to pack the very long cord (overall length 36 m) tightly into the sachet so that it remains 'smooth'. The cord can be pulled out of the sachet extremely easily, as confirmed in a practical test. Conversely, putting an extracted section of cord back into the sachet is impossible.

The BSU believes that this technical aspect suggests that during the last service a longer section of cord glided out of the sachet unintentionally, which – because it could not be put back into the sachet – was then stored next to/in front of the sachet when the liferaft was packed in the container. When tension was applied to the cord due to the liferaft's buoyancy after it was released, a direct transfer of force from outside the container to the painter sachet was not possible but rather the tractive force acted on the section of cord in front of/next to the sachet or the ball that had developed there. This section of cord caught inside the container between the tightly packed liferaft and housing. Inevitably, the cord was then unable to escape from the sachet. In other words, the painter/release cord was unable to run out and the liferaft was held underwater by the obstructed cord.

For the sake of completeness, after reviewing the issue with the cord, the liferaft was removed from the container and its inflation process activated by pulling on the release cord. The liferaft inflated as per its design very quickly and without any problems (see **Fig. 52** below) and was then ready for use.



**Figure 52: Manual activation of the inflation process**

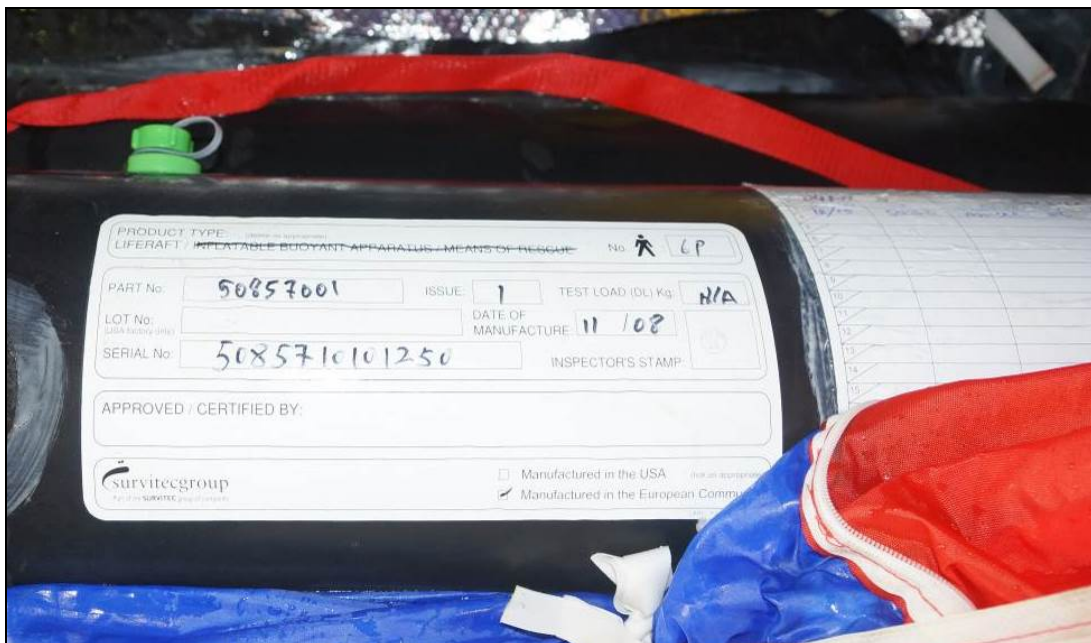
Ref.: 44/16

The ensuing assessment of the liferaft revealed no indication of any technical defects. The required items of equipment were also present.

As notified in the preliminary discussion, an entry for the service carried out in December 2015 was found inside the liferaft.



**Figure 53: References to serial number/manufacturer/completed services**



**Figure 54: Close-up of manufacturer information and serial number**



**Figure 55: Close-up of the service record in December 2015**

Making the entry at the position in question proves that the liferaft was actually removed from the container when it was serviced.

Referencing the legal powers, it was agreed at the end of the meeting that the BSU would send a formal request to DSB with a view to obtaining all necessary technical documentation on the liferaft, information on the authorisation of service stations and any measures taken by the manufacturer as a consequence of the accident.

DSB answered the written questions from the BSU on time and fully. The certificates issued for the liferaft and the service manual were submitted. DSB provided the following information with regard to the selection of service stations and training of local staff<sup>27</sup>:

**"Selection of new service stations"**

*All service stations are selected in accordance with the criteria laid down in the approval procedure of the Survitec Group. The Survitec Group conducts its approval procedure in accordance with IMO Resolution A.761(18). The purpose of this approval programme is to ensure the service station has qualified staff and systems in place for training, monitoring, testing and reporting. The Survitec Group's selection procedure includes but is not limited to a review of the following points:*

- *profile of the service station's organisation and management;*
- *service station's experience in this particular field;*

<sup>27</sup> Source of the following italicised text: Reply of the DSB to the BSU of 8 April 2016.

- *list of engineers indicating their training and experience in the relevant service area, including qualifications according to recognised national, international or where appropriate industry standards;*
- *lists and data formats for recording the findings of servicing carried out by the service station;*
- *record of approvals/recognitions by other certification bodies, and*
- *review of the service station's quality management system, including the management and calibration of equipment, training programmes for engineers, workflow monitoring and review, information gathering and reporting, and a recurrent review of work processes, complaints, corrective actions, document issuance, maintenance and monitoring periodically.*

*If the selection procedure is successful and the service station is approved, then the Survitec Group will issue the service station an approval certificate valid for three years and the service station's engineers are invited to attend a training course. Upon completion of the engineer training course, a certificate of competency is issued, which is valid for three years. The service station signs a written contract detailing the Survitec Group's requirements. All the above points must be completed before the service station can start operation.*

### **Organisation and training**

*To maintain approval, the service station must have a full-time staff member permanently available, who is essentially involved in servicing and testing the equipment and holds a current and valid certificate of competency issued by the Survitec Group. Each certificate of competency is valid for three years from the date of issue. The Survitec Group requires that such employees complete a refresher course at least two months prior to the expiry date of their current certificate of competency in order to be able to renew their certificate.*

*The Survitec Group monitors the approvals and proof of re-testing via its EPR system (CUMULUS). This system records the model and brand of equipment and which employee at the service station is authorised to service the equipment. We operate an electronic certification system, which means that a service station can only issue a service certificate if it has gone through our testing procedures and trained the engineers and if they hold a certificate of competency.*

### **Monitoring**

*The renewal of certificates of approval is carried out at intervals not exceeding three years. Survitec carries out recurrent reviews of the service station periodically to ensure that all approval conditions are met. These reviews include but are not limited to the following points:*

- *agreements and approvals (certificates of approval and signed agreements);*
- *statistics of the service station (number of liferafts serviced each year);*
- *administration (purchase of spare parts and copies of insurance policies);*
- *facilities of the service station (review of the premises);*
- *storage, including safe storage of pyrotechnic materials;*
- *existing tools of the service station;*

- *service instructions and information (including access to all Survitec manuals and proof that the engineers trained in working on liferafts have read and understood all technical information/newsletters);*
- *controlled procedures (for registration and verification, training of engineers and servicing equipment, etc.), and*
- *all safety issues that need to be addressed and resolved.*

*Survitec reserves the right to withdraw or suspend the service station's certificate of approval in a variety of circumstances, including improper performance of a service, improper recording of findings or if an inspector has found defects in the service station's approval system and no remedial action has been taken.*

### **Summary**

*The Survitec Group conducts audits to ensure the effective maintenance of our inflatable liferafts and to provide reliable survival equipment in an emergency.*

*A new service station is given an initial inspection to obtain approval and is then inspected every three years thereafter.*

*When inspecting the service station, it is determined whether the liferafts can be serviced in accordance with IMO Resolution A.761(18) or in accordance with additional requirements for this particular product and design.*

*Survitec's inspection process ensures that every service station approved by us has qualified employees who are trained and certified by us to perform such work.*

*We ensure that all our approved service stations have unrestricted access to the necessary service manuals, technical information, approved spare parts and tools.*

### **Measures taken by Survitec**

*We suspended the service station in question immediately. This station is currently not allowed to service Survitec Group liferafts.*

*We will carry out a re-audit of this station locally and re-train the service engineers immediately. Based on the results of this audit, we will decide whether to maintain or terminate the existing contract with the service station.*

*We have gathered the data on all liferafts of the same configuration serviced by this service station. We are reviewing a recall of liferafts that have not been serviced by another of our accredited service stations in the past year, so as to inspect the rafts and service them again if necessary.*

*Our technical department is also investigating a possible change in the positioning of the painter/release cord sachet to avoid similar incidents in the future."*

*In separate correspondence sent by email dated 11 May 2016, DSB provided the following additional information with regard to the conclusions drawn from the accident:*

Ref.: 44/16

*"In the past week, we sent a Survitec newsletter to all our service stations to once more draw attention to the need to pack/stow the painter/release cord sachet for this type of liferaft correctly.*

*The audit of the service station, DK Safety, has been completed. We have arranged for a recall of the liferafts serviced by DK Safety with the same packing configuration. These will undergo an unscheduled inspection.*

*The two DK Safety service stations are currently suspended. They may not service liferafts for the Survitec Group.*

*We will wait for the findings of your investigation and then decide whether we are able to reapprove the station."*

### **3.3.13 Reconstruction of the course of the voyage on the day of the accident**

#### **3.3.13.1 Preliminary remarks**

Reconstructing the course of the FV CONDOR's voyage on the day of the accident proved very complicated. For lack of carriage requirements, the fishing vessel was not equipped with a VDR (voyage data recorder). AIS<sup>28</sup> signals from the fishing vessel, which otherwise would have been a valuable aid, were not available at the VTS because the AIS transmitter on board the fishing vessel had not been switched on during the day of the accident for reasons that could no longer be explained.

Consequently, the BSU attempted to obtain information about the course of the voyage from the navigation devices installed on the fishing vessel's bridge.

To this end, the following navigation devices were dismantled on the bridge during the first survey of the fishing vessel after she was put ashore at the buoy yard in Hohe Düne, Rostock:

- (1) SIMRAD AP35 autopilot control unit
- (2) Shipmate RS 5310 GPS receiver
- (3) FURUNO GP-32 GPS receiver



**Figure 56: AP35 autopilot control unit**

---

<sup>28</sup> AIS: Automatic identification system. Participants in the system (vessels) transmit vessel-specific information and GPS-based track data in real time, which enable receivers (vessels, shore stations) to analyse and store these data.



**Figure 57: RS 5310 GPS receiver**



**Figure 58: GP-32 GPS receiver**

Immediately after dismantling, the units were placed in a container with distilled water to delay the corrosion process within the respective electronics, which would have been accelerated by the now unobstructed supply of oxygen after the fishing vessel was lifted. In securing the aforementioned units it was hoped that their internal memory data could (still) be read so as to draw conclusions about the track data of the fishing vessel on the day of the accident.

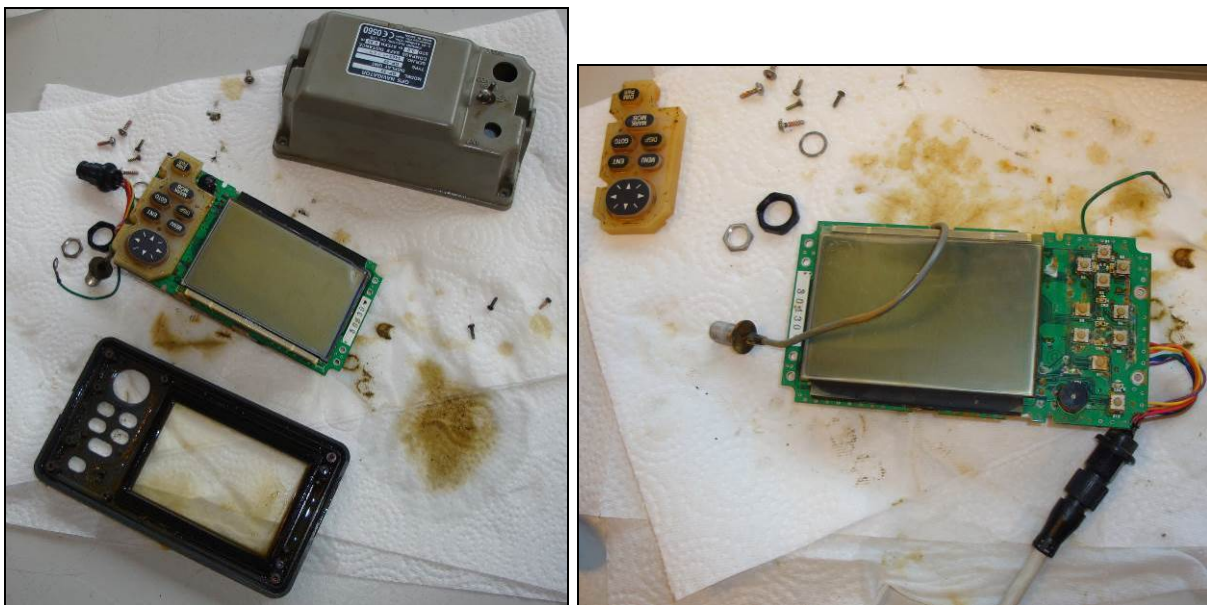
The BSU asked the German service partners of the unit manufacturers about the possible existence of and technical assistance with reading such data. The Schleswig-based company Navico was contacted with regard to (1) and (2), which responded by advising that the units in question do not record track data.

An enquiry was sent to FURUNO Deutschland in Rellingen with regard to (3). The company's answer revealed that the GP-32 GPS receiver stores the most recent courses but that these data are only maintained by an internal battery. It was



reportedly feared that the battery would have discharged due to the long period of exposure to the water of the Baltic Sea (short circuit).

Nevertheless, FURUNO offered to inspect the device in its own workshop with regard to any data that might still be available. During the ensuing inspection, which was attended by two BSU investigators in addition to the FURUNO engineer, the housing of the GPS receiver was carefully opened. A voltage measurement on the internal battery revealed that it had indeed completely discharged in the meantime. The engineer's attempts to reactivate the GPS receiver by connecting it to an external power source also failed. The main circuit board of the unit's electronics was evidently irrevocably destroyed by the exposure to the seawater, meaning it was impossible to obtain track data from the GPS receiver.



**Figure 59: Attempt to analyse the GP-32 GPS receiver by FURUNO's service department**

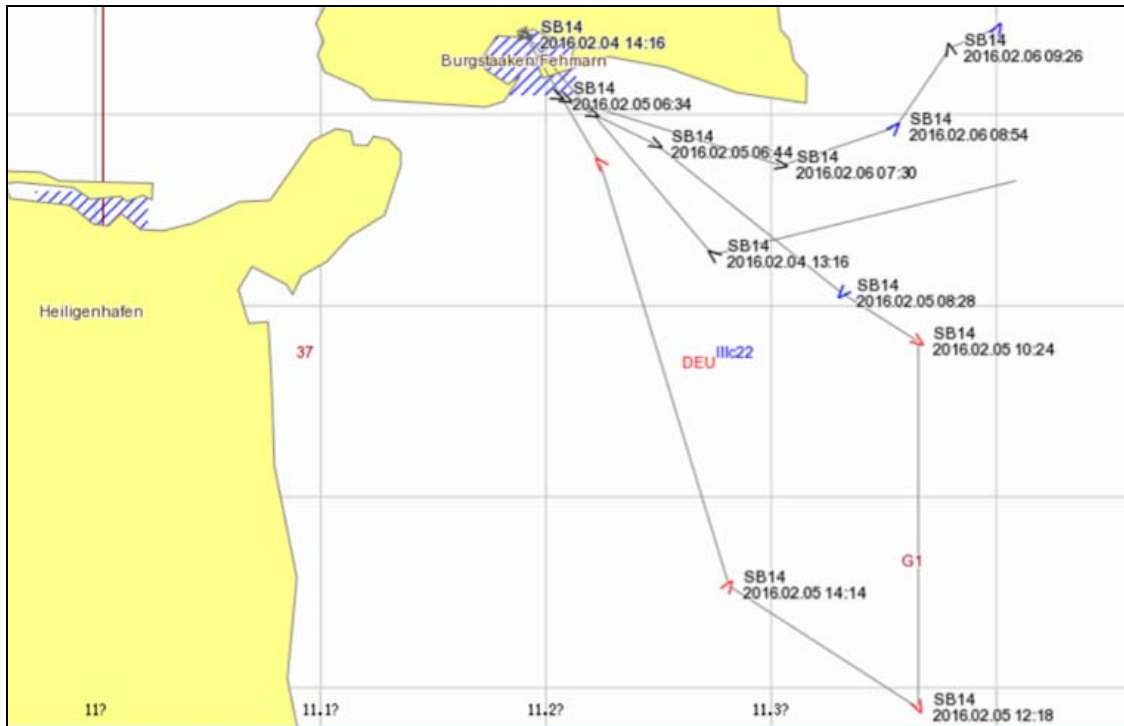
### **3.3.13.2 Analysis of the BLE antenna**

#### **3.3.13.2.1 Background information**

The BSU requested assistance from the Federal Office for Agriculture and Food (BLE) immediately after the accident. One of the responsibilities of this German federal authority is fisheries supervision, which involves it monitoring compliance with fishing quotas and adherence to the boundaries of authorised fishing zones. The effective and efficient monitoring of fishing vessels is accomplished through a satellite-based semi-automated system. To this end, every commercial fishing vessel has a special satellite antenna system on board (e.g. the VMS Mini-C Sailor made by Thrane & Thrane).

The system transmits GPS-based track information depending on certain situations (e.g. start of voyage after a longer rest period, stay in certain fishing zones) and in resulting intervals, which is stored and analysed at the BLE.

In response to the BSU's request, the BLE provided the track data for the FV CONDOR for the day of the accident and the two preceding days.



Nation	Ident	Internal Ident	Radio	Name	Status	local time	UTC time	Course	Speed	Lat.	Lon.	Square	EEZ	Int.zone	Harbour
DEU	SB14	DEU301070206	DKAV	Condor	TPREP	04.02.2016 13:16	04.02.2016 12:16	309	8.0	54°21.8	11°16.4	37G1	DEU	IIIc22	
DEU	SB14	DEU301070206	DKAV	Condor	BSPLM	04.02.2016 14:16	04.02.2016 13:16	134	0.0	54°25.2	11°11.5	37G1	DEU	IIIc22	Burgstaaken/Fehmarn
DEU	SB14	DEU301070206	DKAV	Condor	TPREP	04.02.2016 22:24	04.02.2016 21:24	104	0.0	54°25.2	11°11.5	37G1	DEU	IIIc22	Burgstaaken/Fehmarn
DEU	SB14	DEU301070206	DKAV	Condor	TPREP	05.02.2016 06:34	05.02.2016 05:34	112	8.6	54°24.3	11°12.3	37G1	DEU	IIIc22	
DEU	SB14	DEU301070206	DKAV	Condor	ASPLM	05.02.2016 06:38	05.02.2016 05:38	115	8.6	54°24.0	11°13.3	37G1	DEU	IIIc22	
DEU	SB14	DEU301070206	DKAV	Condor	TPREP	05.02.2016 06:44	05.02.2016 05:44	118	8.6	54°23.5	11°15.0	37G1	DEU	IIIc22	
DEU	SB14	DEU301070206	DKAV	Condor	TPREP	05.02.2016 08:28	05.02.2016 07:28	223	2.6	54°21.2	11°19.9	37G1	DEU	IIIc22	
DEU	SB14	DEU301070206	DKAV	Condor	TPREP	05.02.2016 10:24	05.02.2016 09:24	128	3.4	54°20.4	11°21.9	37G1	DEU	IIIc22	
DEU	SB14	DEU301070206	DKAV	Condor	TPREP	05.02.2016 12:18	05.02.2016 11:18	154	3.2	54°14.7	11°21.9	37G1	DEU	IIIc22	
DEU	SB14	DEU301070206	DKAV	Condor	TPREP	05.02.2016 14:14	05.02.2016 13:14	35	3.6	54°16.6	11°16.9	37G1	DEU	IIIc22	
DEU	SB14	DEU301070206	DKAV	Condor	TPREP	05.02.2016 16:10	05.02.2016 15:10	319	4.8	54°23.2	11°13.4	37G1	DEU	IIIc22	
DEU	SB14	DEU301070206	DKAV	Condor	BSPLM	05.02.2016 17:10	05.02.2016 16:10	229	0.0	54°25.2	11°11.4	37G1	DEU	IIIc22	Burgstaaken/Fehmarn
DEU	SB14	DEU301070206	DKAV	Condor	TPREP	05.02.2016 22:24	05.02.2016 21:24	86	0.0	54°25.2	11°11.4	37G1	DEU	IIIc22	Burgstaaken/Fehmarn
DEU	SB14	DEU301070206	DKAV	Condor	ASPLM	06.02.2016 07:02	06.02.2016 06:02	115	6.8	54°24.2	11°12.6	37G1	DEU	IIIc22	
DEU	SB14	DEU301070206	DKAV	Condor	TPREP	06.02.2016 07:30	06.02.2016 06:30	100	8.4	54°23.2	11°18.3	37G1	DEU	IIIc22	
DEU	SB14	DEU301070206	DKAV	Condor	TPREP	06.02.2016 08:54	06.02.2016 07:54	43	2.8	54°23.8	11°21.3	37G1	DEU	IIIc22	
DEU	SB14	DEU301070206	DKAV	Condor	TPREP	06.02.2016 09:26	06.02.2016 08:26	346	7.8	54°25.0	11°22.8	37G1	DEU	IIIc22	
DEU	SB14	DEU301070206	DKAV	Condor	TPREP	06.02.2016 11:22	06.02.2016 10:22	28	1.0	54°25.4	11°24.0	37G1	DEU	IIIc22	

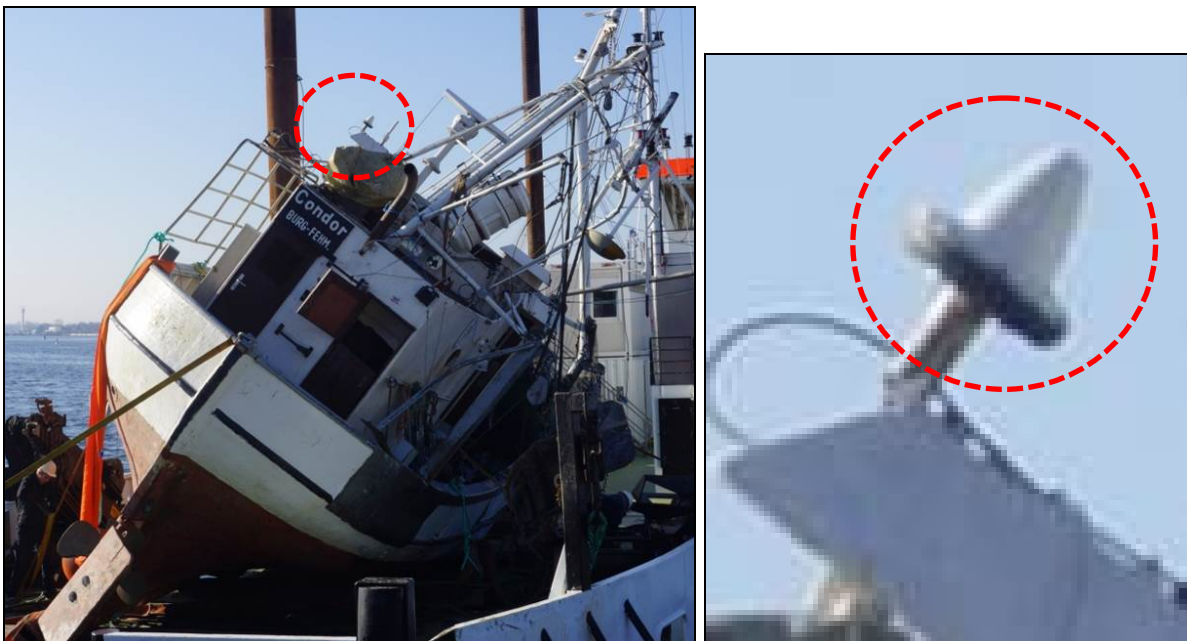
**Figure 60: FV CONDOR's track data for 4-6 February 2016 (source: BLE)**

The above summary shows that the CONDOR carried out one-day fishing voyages during the period under consideration and spent both nights prior to the day of the accident in the home port of Burgstaaken, Fehmarn. It is also evident that the recording of the track data only took place in a very sparse pattern, as provided for by the system and required. A reconstruction of the course of the voyage on the day of the accident using these data was therefore not possible.

For this reason, the BSU asked the BLE whether further data could possibly be made available internally within the device and received the following reply from the BLE's service company iks – Ingenieurbüro Klaas Schlenkermann:

*"The VMS Mini-C is not able to send a position report if a ship founders spontaneously. The antenna may have been submerged first or the power supply may have failed. The internal GPS receiver loses the signal when it submerges. Any function stops immediately in the event of a power loss because it does not have its own power supply. In both cases, the last position received is still stored in the device. The devices also have an internal data logger function, which stores positions at shorter intervals and greater accuracy than they are sent. It might be possible to read out position data if the device was found. GPS reception must be shielded when reading out the last position or the last position would be overwritten by a newer one. The device interface is password-protected. The password can be provided."*

The BSU took up the suggestion of the service company and arranged for the antenna to be dismantled.



**Figure 61: Position of the BLE antenna on the FV CONDOR**

It was a Mini-C TT-3026 INMARSAT C antenna made by Thrane & Thrane. Antennas of this type have been in production for several years. They are a very widespread and proven model for various bi-directional satellite communication applications. In addition to a transmitter, a GPS receiver is installed in the antenna.

The BLE's service company made a technical modification to the antenna for fisheries surveillance applications so that it – in accordance with the requirements/specifications of the BLE – regularly, i.e. about every two hours, transmits a file containing the course, position and speed (TPREP status message), which is recorded by the BLE.

The antenna system has been designed so that the costly satellite data transmission is not made again if the vessel's position remains unchanged, but only re-starts when another change in position occurs.

In practical operation, this means that the antenna transmits a BSPLM status message if the position does not change for more than 15 minutes (i.e. in particular, if the fishing vessel is anchored or made fast in port) and a so called ASPLM status message (again with a 15-minute delay) when the fishing vessel's position has changed again (i.e. when she sails out of port). An additional TPREP status message is also transmitted whenever the BLE initiates one from ashore by means of a specific query.

Moreover, the antenna is programmed to store internally the position, course and speed on a password-protected non-volatile memory every hour (in the clock rate independently of the aforementioned automated position transmission intervals). The ring buffer has a capacity of 3.5 years. The storage capacity in newer devices (not the one installed on the FV CONDOR) is greater. Accordingly, the service company has programmed a 20-minute memory cycle here.

The service company has concluded service contracts with fishing vessel operators. It is able to access antennas at any time via tele-maintenance, to check their functionality and, for example, to query data stored in antennas if necessary.

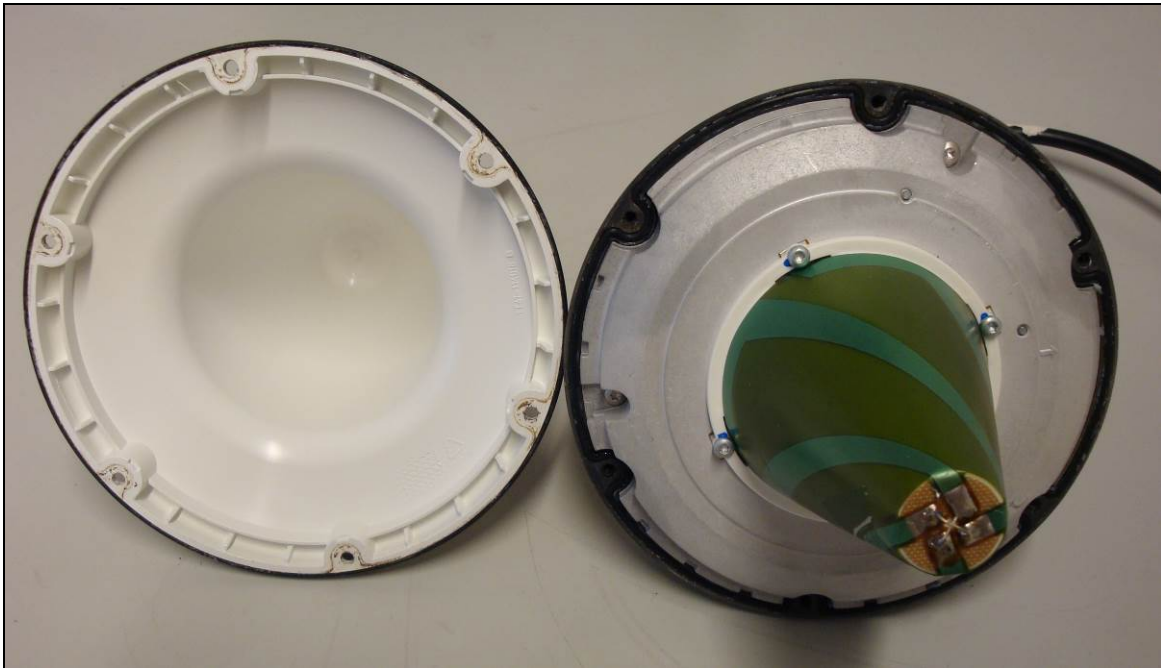
#### 3.3.13.2.2 Reading the antenna data

In preparation for the appointment for reading the antenna data, the service company asked the BSU to open the antenna housing, so as to clarify beforehand whether seawater had reached the interior of the device. It is likely this would have destroyed the sensitive electronics.

Although the antenna is basically not designed to withstand a prolonged period of submersion in water, when it opened the housing the BSU found that no moisture had reached the interior of the antenna (see **Fig. 63** below). This vastly improved the chance of obtaining usable information from the antenna's memory.



**Figure 62: The BLE antenna exhibiting no visible damage**



**Figure 63: Opened antenna housing without any traces of moisture**

On 14 June 2016, the service company read the data stored in the antenna in the presence of two investigators at the BSU. To this end, the antenna was connected to a special printed circuit board, which in turn was connected to a computer. In addition, an adjustable power supply unit was connected to the board to power the antenna's electronics (see **Fig. 64 f.**).

A Microsoft program for WinXP (HyperTerminal) was used as the connection and reading software. This program makes it possible to read the files stored in the antenna and then to write these files (or their content) – as soon as they are opened with the software and viewed on a computer – to a log file, which can be stored on a computer and accessed later (without the need to connect to the antenna).

To prevent the last track information stored automatically when the antenna failed (time at which connection to the satellite was interrupted/antenna submerged/time of foundering) from being overwritten by new GPS information after the antenna was automatically activated by supplying it with power, the antenna was temporarily shielded as a precautionary measure by placing a metal container over it before the power was switched on.

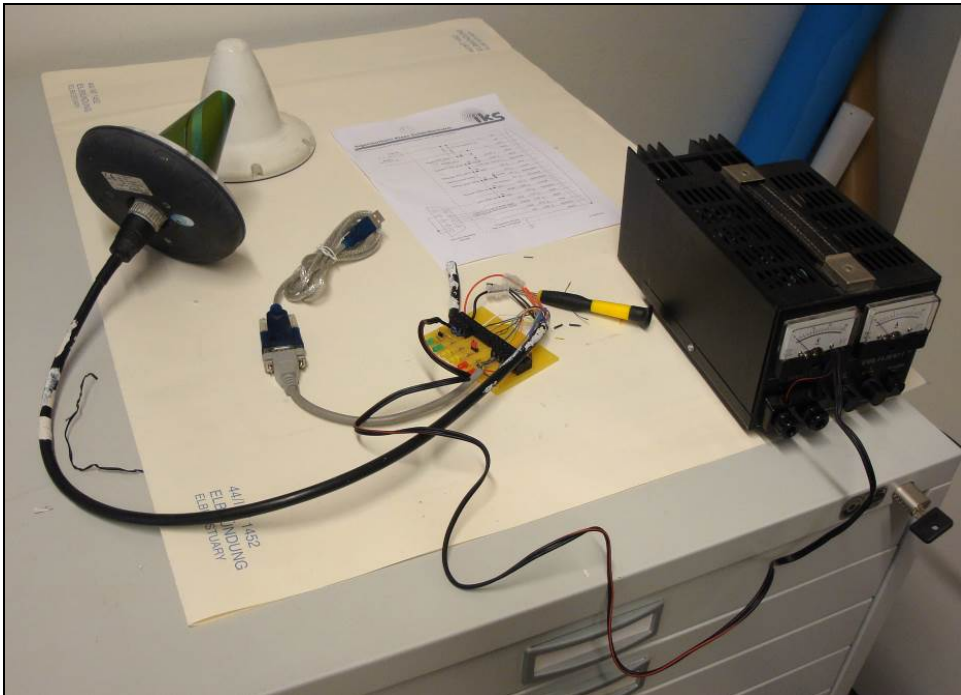


Figure 64: Technical preparatory measures for reading the antenna data (1)

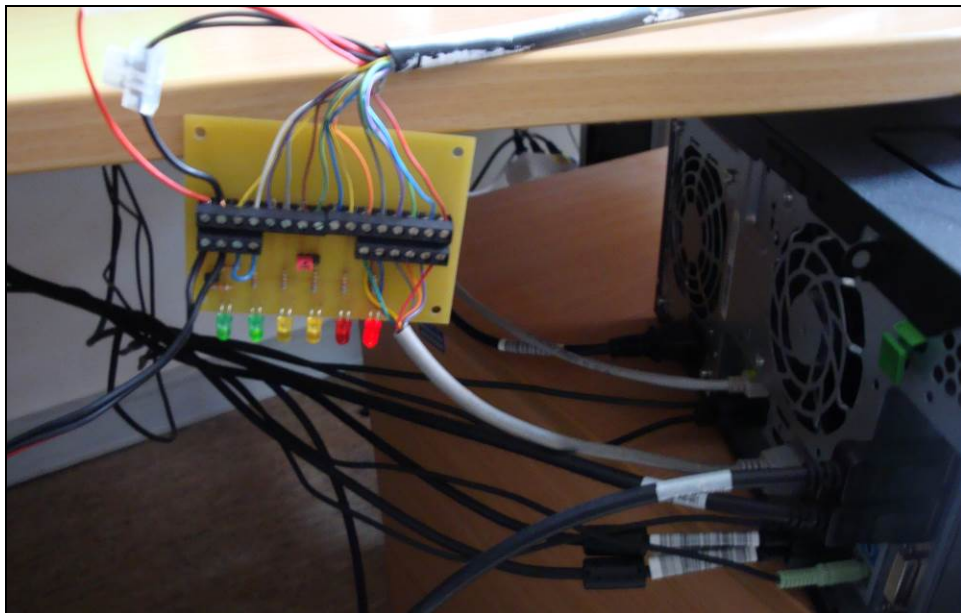


Figure 65: Technical preparatory measures for reading the antenna data (2)



**Figure 66: Shielding the antenna with a metal container**

After all the preparatory measures had been completed (i.e. cable connection of the antenna to the computer and reading software launched), the antenna's power supply was activated. The active connection to the antenna was immediately visible in the aforementioned WinXP program. Special DOS commands made it possible to access various files stored on the antenna. The data appeared on the computer screen in readable form and included information on the antenna's operating status (time it was switched on or off manually) and sea weather data received by the antenna, for example.

In addition to other information, the time of the last recorded track information was displayed, which was of particular interest to the BSU. This was stored as per its design when the GPS satellite connection was interrupted (in this case when the antenna was submerged) at 1036 UTC (see **Fig. 67**).

```

SB14.Mini-C.log - Editor
Datei Bearbeiten Format Ansicht ?

SOFTWARE:   Version 2.26 Jul  6 2009 09:13:42, Inmarsat-C Transceiver

Synchronization : no                Serial no      : 4125283
Logged in       : yes               Mobile no     : 421117410
TDM type        : -                 Preferred ocean : None
TDM channel number : 12580          Activities in queue
Current channel  : Retuning          1 : Enhanced data report
Current protocol : Changing NCS
TDM origin      : -
TDM frame number : -
BB error rate   : 0 of 100
: ru -g

Test Summary: Error 8000H      00 visible satellites  SW Version 2.3.02
Navigation Mode: 1 FOM: 1 UTC: 1
Accept Altitude: 0 Hold: 0 VPerr: 0 m
PDOP: 50 HDOP: 50 HPerr: 0 m
Elevation mask: 00 HVerr: 0 cm/s

Satellite Tracking Status
Satellites:
Signal Level:
Elevation:
Azimuth:

V. Speed : 0 ft/m Altitude: 106 ft
Position : 54 25 22 N 011 23 88 E at 10:36:05 UTC
Course : 023 deg/true north
Speed : 0000 knots : 0001 kmph : 0000 mph
: st -o e

```

**Figure 67: Information on the fishing vessel's last stored position before the antenna signal was interrupted (the time of foundering)**

In addition to the above data, a DOS command also made it possible to read that there was a battery failure, i.e. the antenna's power supply (realised via the regular on-board power system (battery)) failed, at 1057 UTC. (According to the service company, the 'late' time at which the battery failed does not contradict the submersion of the antenna 20 minutes earlier. The battery will continue to function under water until it short circuits and fails, for example.)

The antenna's data also showed that it had the latest firmware and that system failures or other irregularities had not happened in the past.

In addition to the above data, the service company's expert could also access the password-protected hexadecimal-coded log file and define an individual download period. A period before the start of the fishing voyage on the day of the accident (6 February at 0500 UTC) up until when the fishing vessel foundered was defined for the purposes of the investigation. The log file stores various antenna information, the entire decryption of which is very complex, for a total period of 3.5 years.

For the BSU's purposes, it was of particular interest whether the log file (hourly memory cycle) contained track information between the last track information sent regularly and stored by the BLE (1022 UTC) and that stored internally when the antenna submerged (1036 UTC).

The service company's expert offered to decode the log file with this in mind.

On 16 June 2016, the service company provided the track information (times in UTC) obtained with the help of *Polaris A/S Aalborg* by decoding the log file:

Time (GPS)	Received	Type	Latitude	Longitude	Speed [kts]	Course
02/06/2016 05:09:22	02/06/2016 05:09:22	Request/Timecycle	N54 25.2450	E11 11.4250	0.0	116°
02/06/2016 06:09:22	02/06/2016 06:09:22	Request/Timecycle	N54 23.9900	E11 13.7150	3.8	108°
02/06/2016 07:09:22	02/06/2016 07:09:22	Request/Timecycle	N54 23.9100	E11 21.8000	1.7	42°
02/06/2016 08:09:22	02/06/2016 08:09:22	Request/Timecycle	N54 24.1600	E11 22.4600	1.5	92°
02/06/2016 09:09:22	02/06/2016 09:09:22	Request/Timecycle	N54 25.2900	E11 21.6700	2.3	348°
02/06/2016 10:09:22	02/06/2016 10:09:22	Request/Timecycle	N54 25.7000	E11 23.8200	0.9	16°

The summary shows that the internal storage is made in the ninth minute of each hour, meaning it was not possible to obtain track information between the times already known at 1022 UTC and 1036 UTC (transmission to the BLE and submersion of the antenna respectively).

### 3.3.13.2.3 Findings of the analysis of the BLE antenna

Unfortunately, the findings of the analysis of the INMARSAT C antenna are only of limited value to the BSU. However, the exact time of the accident (1036 UTC) and corresponding track data (position, course, speed) could be determined with a probability bordering on certainty.



### 3.3.13.3 Analysis of the radar image recording from the VTS

VTS Travemünde provided the BSU with a technically enhanced radar recording (video file) of the day of the accident, which shows the course of the FV CONDOR's voyage before the marine casualty occurred. The video created by the VTS displays the FV CONDOR's radar echo and her course and speed continuously. This information is the result of electronically assisted radar image analysis. Due to the error sources inherent in each radar image analysis system, they have only limited informative value and must not be compared with GPS-based track data in terms of accuracy and reliability. However, the following screenshots have been selected from the video of the VTS, as they provide at least a rough overview of the course of the fishing vessel's voyage immediately before the accident. (The fishing vessel's echo is marked by a red circle.)

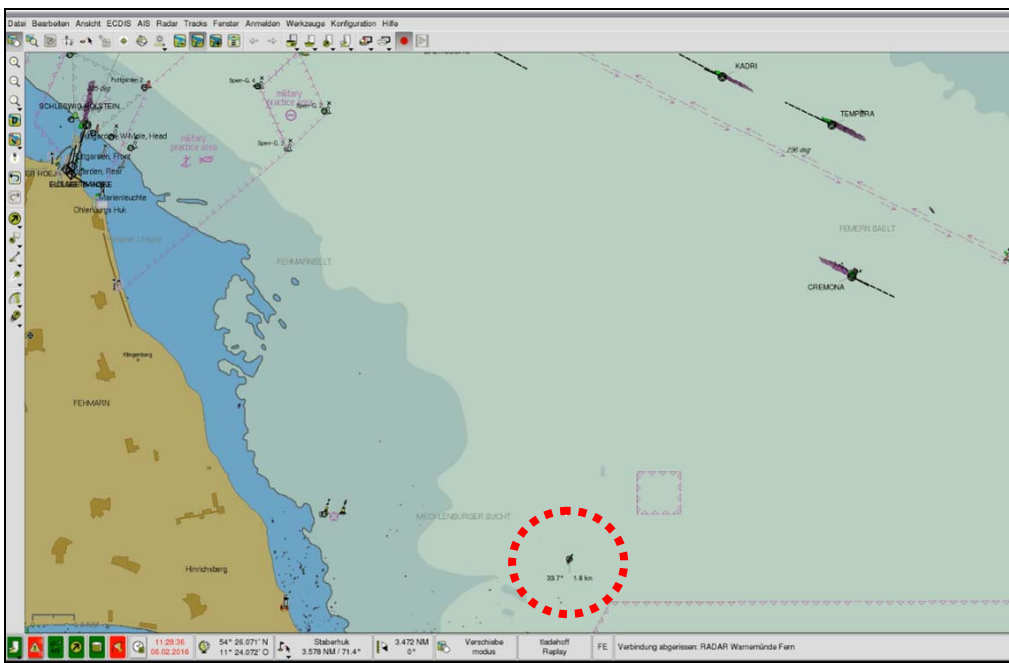


Figure 68: Complete screenshot from the radar video of VTS Travemünde<sup>29</sup>

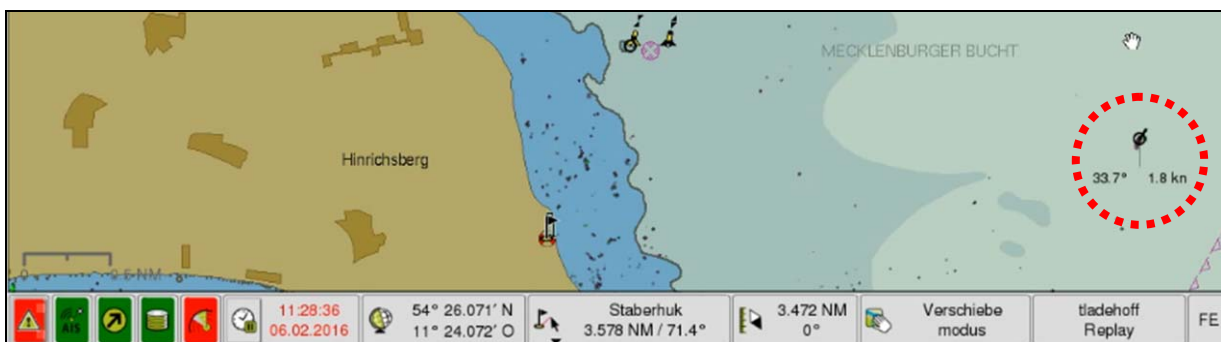


Figure 69: Radar echo of the FV CONDOR at 112836

<sup>29</sup> Fig. 68 gives an overview of the total format of the submitted video. In each case, the following individual frames selected by BSU were reduced to the required detail.

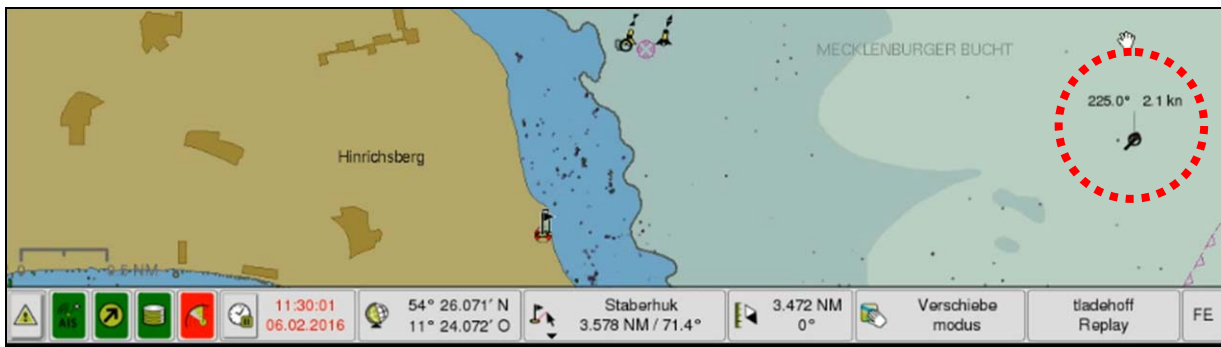


Figure 70: Radar echo of the FV CONDOR at 113001

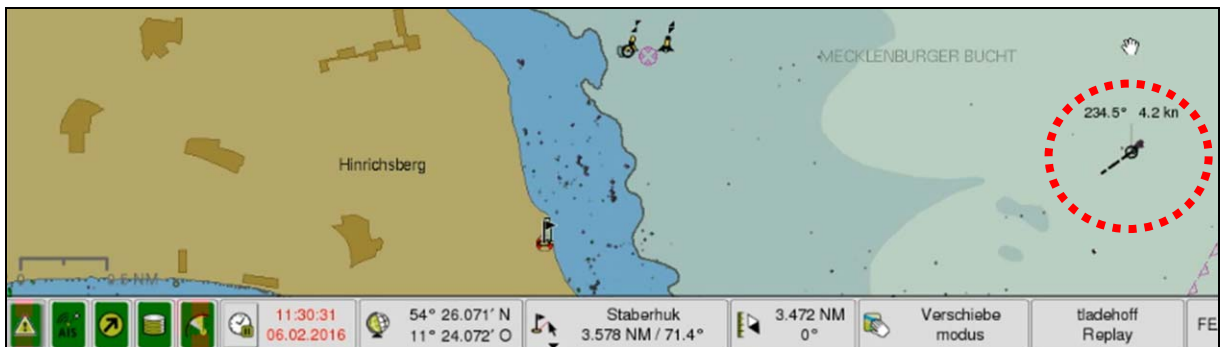


Figure 71: Radar echo of the FV CONDOR at 113031

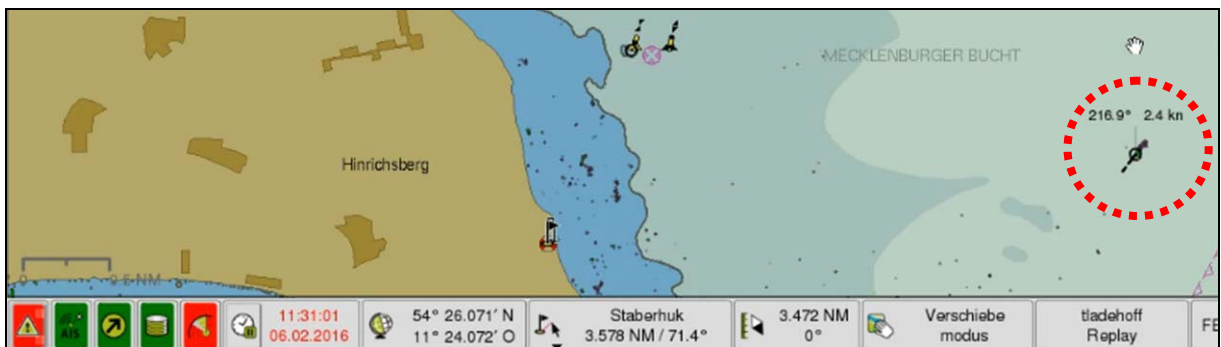


Figure 72: Radar echo of the FV CONDOR at 113101

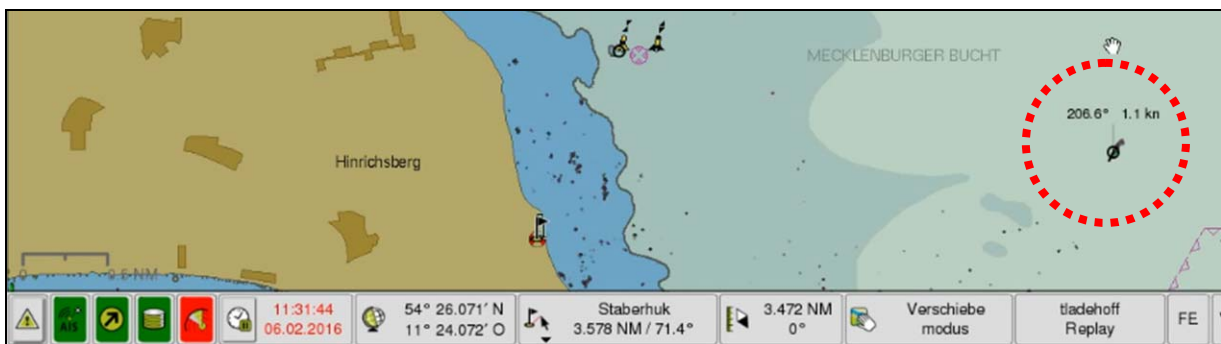
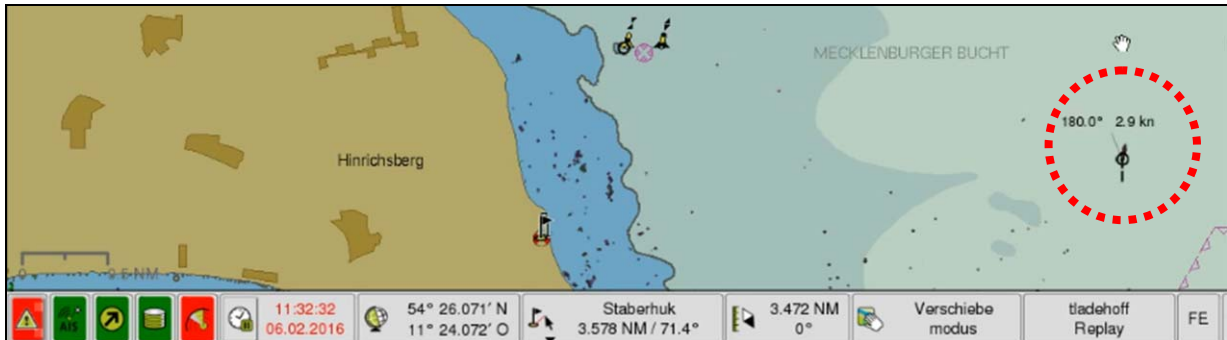
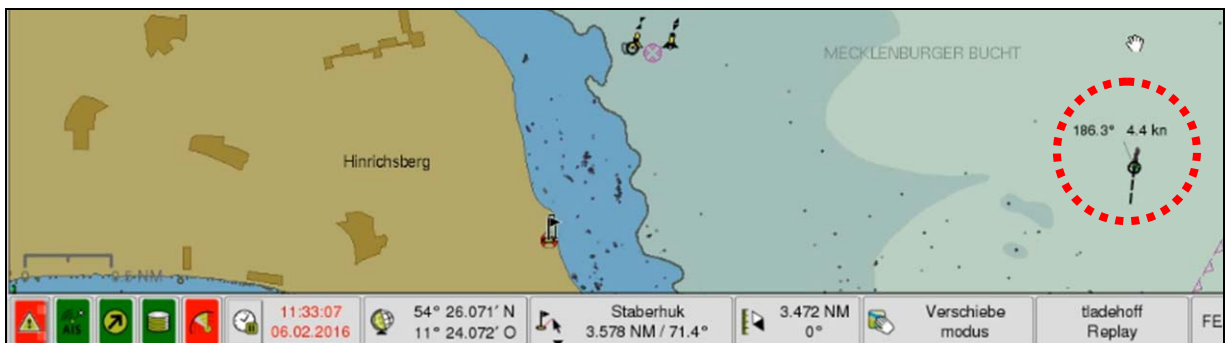


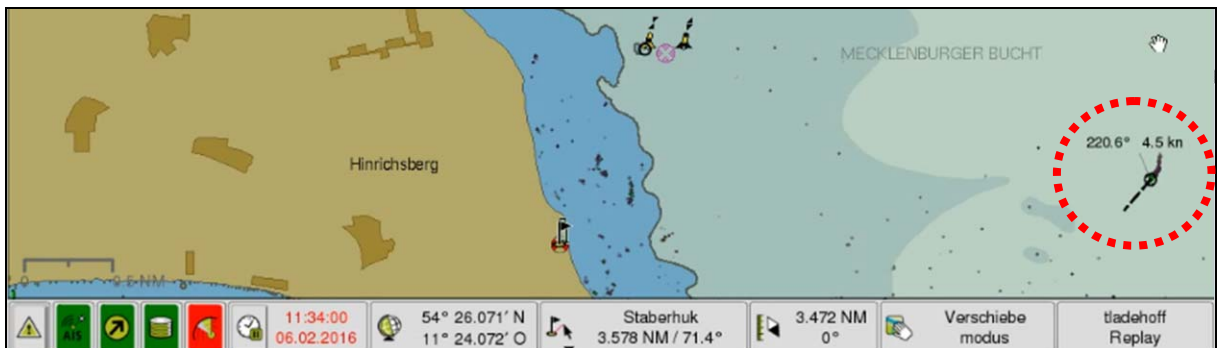
Figure 73: Radar echo of the FV CONDOR at 113144



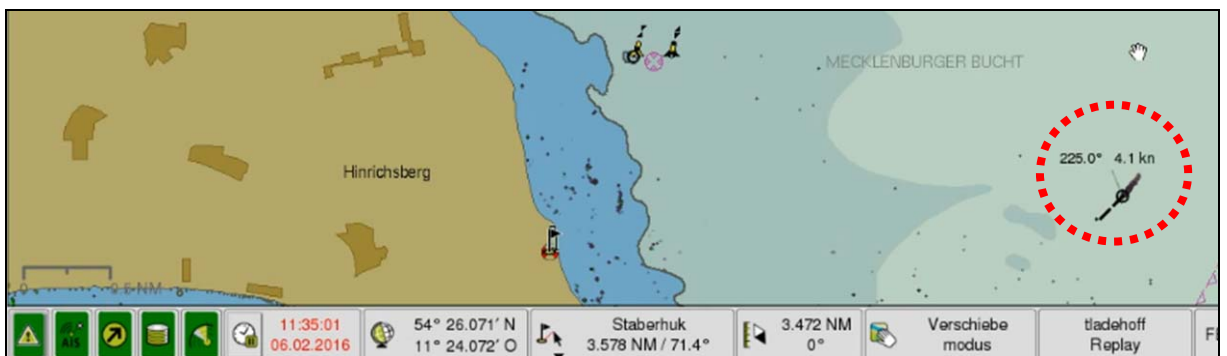
**Figure 74: Radar echo of the FV CONDOR at 113232**



**Figure 75: Radar echo of the FV CONDOR at 113307**



**Figure 76: Radar echo of the FV CONDOR at 113400**



**Figure 77: Radar echo of the FV CONDOR at 113501**

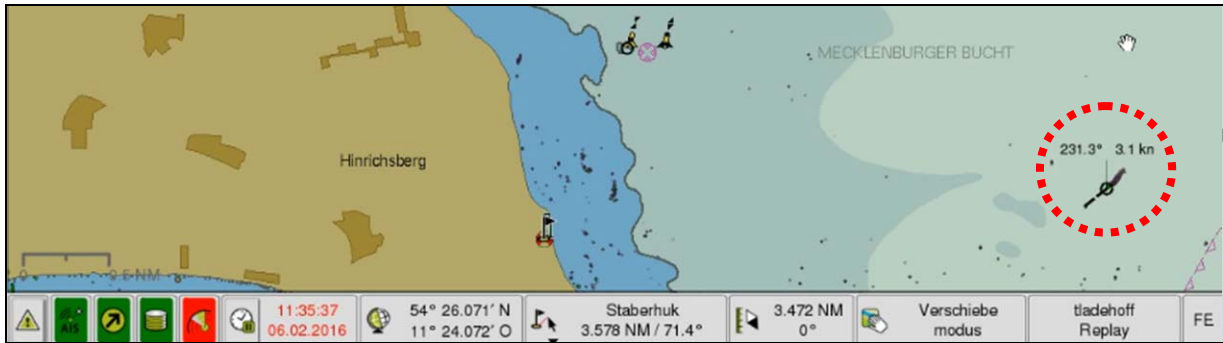


Figure 78: Radar echo of the FV CONDOR at 113537

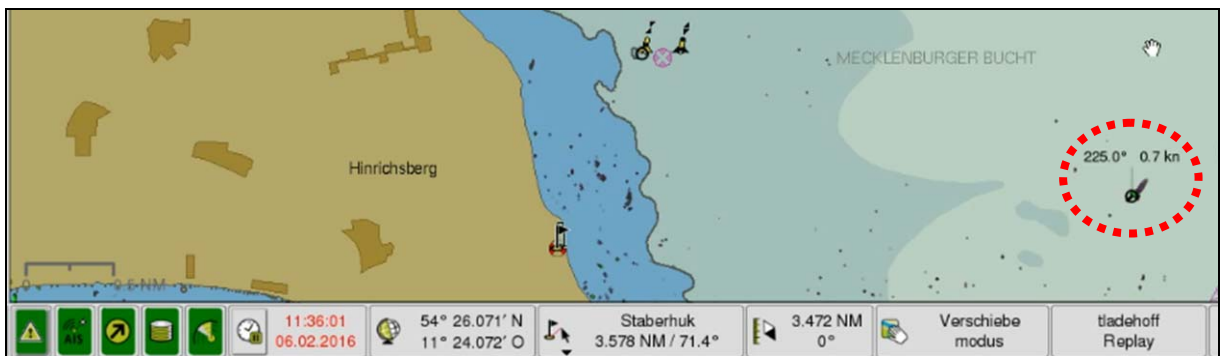


Figure 79: Radar echo of the FV CONDOR at 113601

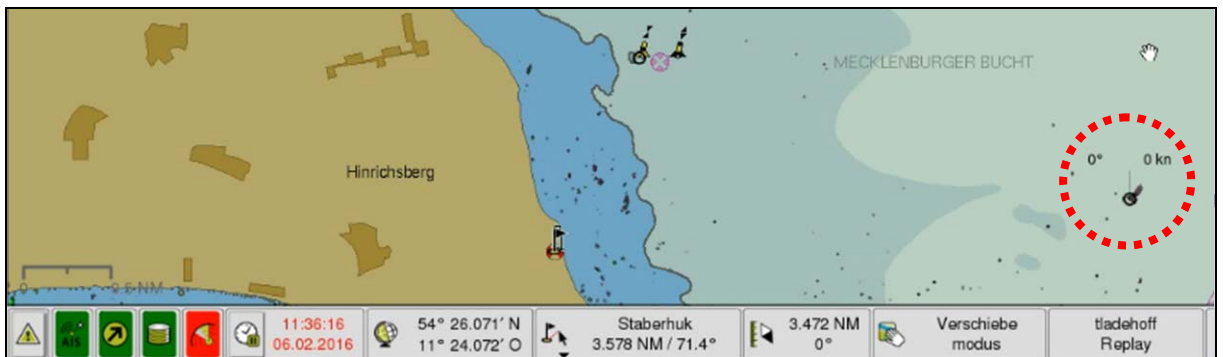


Figure 80: Radar echo of the FV CONDOR at 113616

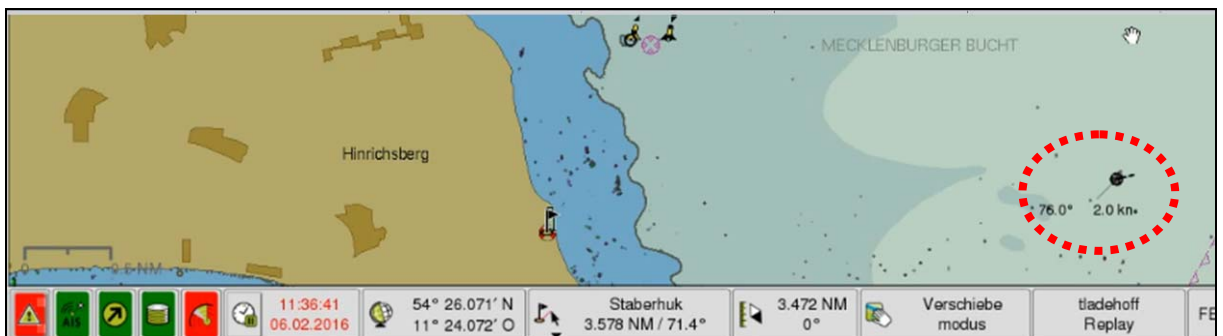
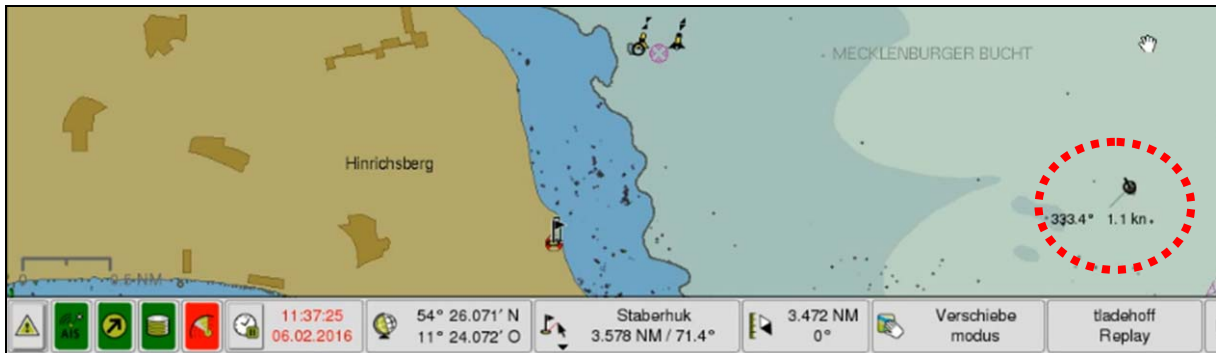
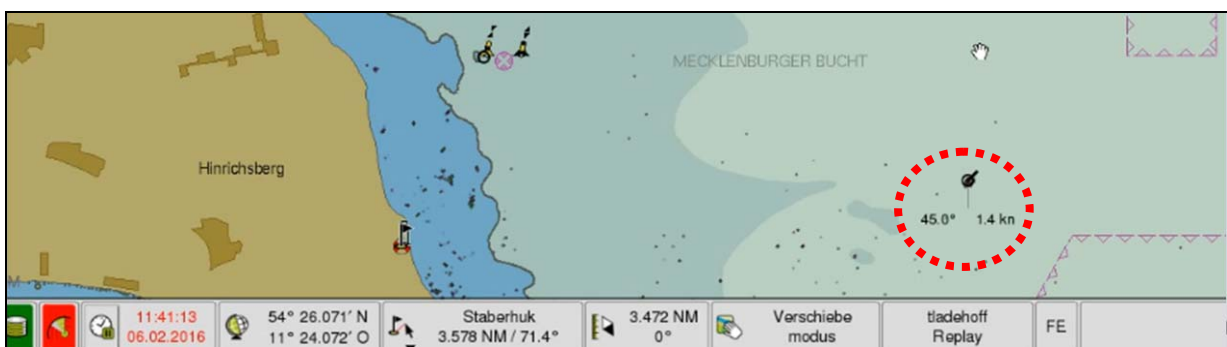


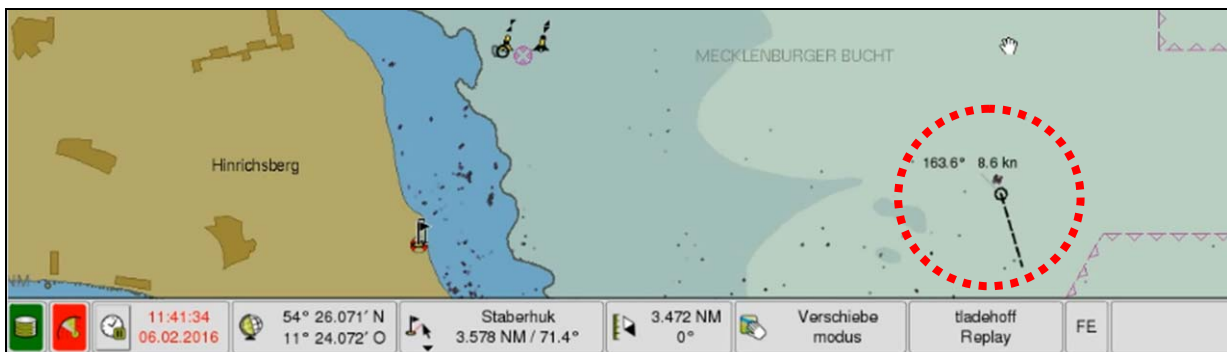
Figure 81: Radar echo of the FV CONDOR at 113641



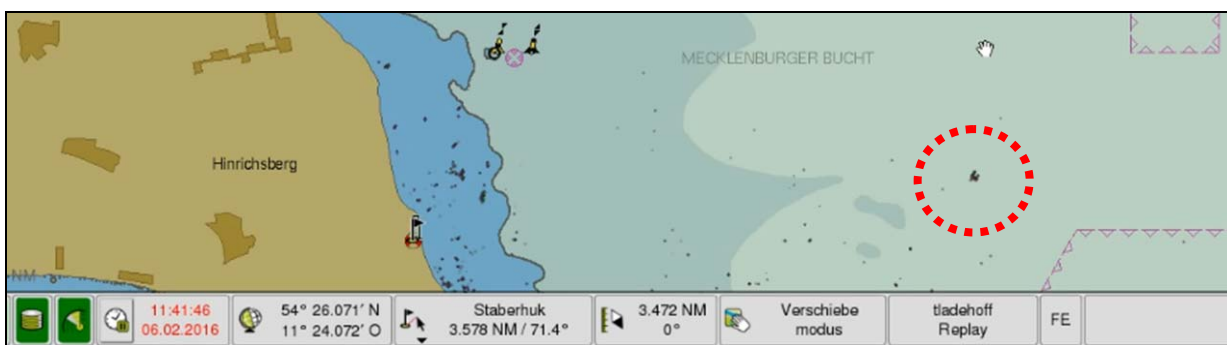
**Figure 82: Radar echo of the FV CONDOR at 113725**



**Figure 83: Radar echo of the FV CONDOR at 114113**



**Figure 84: Radar echo of the FV CONDOR at 114134**



**Figure 85: Radar echo of the FV CONDOR at 114146**

The above radar images indicate that the FV CONDOR slowly picked up speed shortly before 1130 to head for her home port after the end of the fishing voyage on a south-westerly heading. This assumption is consistent with the fact that the skipper of the fishing vessel used his mobile phone to call his colleagues at the fishermen's cooperative in Burgstaaken at the same time and basically advised them that the fishing activities were productive and they were now returning to port.

The speed of the fishing vessel, which had previously reached 4.2 kts, slowed down between 1131 and 1132 but then increased again in the following minutes, before abruptly dropping to zero at 1136. In this respect, there is a clear concordance with the findings of the analysis of the BLE antenna, the memory of which had the time of the interruption of the GPS signal at 113605, for which submersion of the antenna is considered to have been the most likely cause, recorded as the last event.

Despite the generally known uncertainties inherent to every radar detection system, it initially seemed inexplicable to the BSU why the echo of the fishing vessel was still visible on the radar video for a longer period after the time of the accident indicated by both the radar image and the BLE antenna (**1136**) and why a speed of more than 8 kts was even indicated for the fishing vessel at **1141**, before the echo suddenly disappeared.

The BSU contacted the BLE expert with regard to this issue. In this respect, the latter gave the following (summarised and moderately edited) considerations, inter alia:

*"[...] The determined position on the GPS system is always linked directly to the highly accurate time information. Accurate time information is needed to determine the position. The Inmarsat device always retains the last determined position with time stamp in its memory, until this is overwritten by a new position. Therefore, we can be sure that this is the last determined position. There was no temporary interruption in the power supply to the Inmarsat C antenna, as such an event would have been recorded in the analysed log file.*

*Experience in fisheries surveillance tells us that there have been a few cases where position reports contained incorrect time stamps. The causes determined were*

- *wrong offset for the time zone (the error here is in whole hours);*
- *GPS processor hangs (the same position was always transmitted over an extended period of time, absent validity check);*
- *corrupt firmware (this error would also affect the earlier position reports and would be visible in the VMS server);*

*All these causes can be excluded.*

*Provided the time stamps of the radar system are correct, the following options for the (seemingly) divergent foundering times are still possible:*

*GPS reception of the Inmarsat C antenna, which normally detects an updated position every second, may have been disturbed due to heeling heavily or shadowing from hoisted nets.*

*However, it is likely that more than 50% (depending on the satellite constellation at the time of the accident) of the visible sky area would have been covered to prevent the analysis of satellite signals. This would probably only be possible due to an object near the antenna and not due to a heel of less than 90°.*

*It is also conceivable that a hoisted, full net is suspended on the antenna but this is unlikely due to the antenna's position.*

*In addition, the fishing vessel may have capsized and issued a radar echo until she sank completely. [...]"<sup>30</sup>*

All in all, based on the information provided by the expert acting on behalf of the BLE, the BSU assumes that although an error in the recording of the foundering position by the BLE antenna cannot be ruled out completely, it is highly unlikely in the case at hand.

This reinforced the assumption that either errors in the time stamp of the radar recording or with regard to the analysis of the radar image and interpretation could be responsible for the discrepancy between the two presumed foundering times.

With regard to the reliability of the radar recording's time stamp, the BSU made a request to Maritime Verkehrstechnik (VT – maritime traffic engineering), which is the bundling unit responsible internally for the technical support of the radar systems of the Federal Waterways and Shipping Administration (WSV), and received the following reply:

*"The technical installation times of the maritime traffic engineering system are synchronised via our own network. To this end, WSV operates highly accurate iridium time sources at three different locations. We are not aware of these time sources (triple redundancy) failing at the time of recording. Since such a failure would have affected all maritime traffic engineering systems on the German coast, but was not detected, I would rule this out."<sup>31</sup>*

As regards a possible misinterpretation of the radar images, the BSU finally referred to the German company in-innovative navigation GmbH in Kornwestheim. Alongside other lines of business, this company has vast experience in the field of technical equipment for VTSs, and thus inevitably also in the field of radar video processing. The BSU sent this company the radar video and asked for assistance with its interpretation.

The managing director of in-innovative navigation GmbH, who is responsible for projects and was instrumental in the development of the maritime traffic engineering monitoring system, responded to the BSU's request immediately and stated the following as a result of his observations:

---

<sup>30</sup> Source: Email from the expert acting on behalf of the BLE to the BSU of 22 September 2016.

<sup>31</sup> Source: Email of the maritime bundling unit VT to BSU of 23 September 2016.

*"[...] A radar target with a very low speed and unclear course is visible up until 114113. At such low speeds, we must not pay too much attention to the heading, however. Presumably the ship has only made good a few hundred metres. At 114134, the CONDOR had already disappeared from the radar screen and sea clutter was misallocated to the track.*

*When interpreting the recording, it should be noted that the afterglow was activated in the radar image when the recording was made. The afterglow appears in a lilac-grey shade that is slightly transparent. The current radar image is displayed in green. The images suggest to me that the target had definitely already disappeared from the radar screen at 114134, whereas the radar afterglow is still clearly visible at her last position. Due to the relatively small (zoomed out) image, it is difficult for me to assess at exactly what time a radar echo was actually last visible. Since a minimal alteration in course was made between 114053 and 114113, I assume that one radar measurement was allocated at this interval at least.*

*The sudden acceleration at 114134 is probably a false measurement caused by the foundering and ensuing loss of a real radar measurement. The tracking method searches for a suitable radar object in each radar scan and then allocates its measurement data to the track. However, if a ship founders, then she disappears from the radar screen completely and therefore no radar object is found at the predicted position.*

*The tracker does not give up immediately in such a case, instead the target is extrapolated further on the old course and the search area gradually expanded. In the case of extremely small targets, a temporary loss of measurement may occur even without a foundering incident due to fluctuations or shadowing. In the event of the FV CONDOR foundering, no suitable echo was found even after several radar scans and the search area was therefore already unusually large.*

*Finally, sea clutter (radar echo from swell) was allocated, which was found a little to the south and most likely had nothing to do with the incident. The radar installation at Staberhuk is extremely sensitive and our automatic threshold filters always try to detect radar objects up to the detection limit. That many false measurements are recorded in the process is normal. However, complex filters prevent false measurements from immediately appearing on the screen as targets. Only when a target exhibits comprehensible behaviour for an extended period will the track be shown on the display system. However, once a track has reached this state, the tracker will attempt to follow the target for as long as possible (after all, a ship cannot normally simply disappear), even in the event of a sudden course alteration or brief concealment by a shadow. The track is aborted only if no comprehensible behaviour is exhibited for an extended period or if no measurements are found at all. This is obviously the case at 114146 in the recording under review. [...]"<sup>32</sup>*

### Conclusion of the BSU

Based on all the above considerations, the BSU concludes that the FV CONDOR most likely capsized at 1136.

---

<sup>32</sup> Source: Email Dr. Zimmermann (in-innovative navigation GmbH) to the BSU of 22 September 2016.



The BLE antenna submerged, causing an interruption to the GPS connection and storage of this event in the antenna. The echoes that remained visible until 1141 in the radar recording of VTS Travemünde are most likely due to the fact that the fishing vessel did not founder completely immediately after capsizing.

The initially only partially submerged wreck of the CONDOR, possibly floating equipment, the high sensitivity of the relevant shore station, and the fact that the shore station attempts to follow a target once identified for as long as possible are the likely reasons for the fact that the echo did not actually disappear completely from the radar screen until five minutes after the time at which the CONDOR capsized.

### **3.3.14 Investigation of the engine and the winch control**

#### **3.3.14.1 Preliminary remarks**

As with the previous dives on the wreck, it was not possible to find any obvious causes for the fishing vessel foundering after she was salvaged. Consequently, the BSU was compelled to investigate in different directions. One of the main topics was whether technical problems on board the CONDOR in the area of her engine, the rudder or the winch control might have played a role in the accident. In a letter dated 25 April 2016, the BSU asked Prof. Dipl.-Ing. Hark Ocke Diederichs to assess the fishing vessel's technical equipment.

Professor Diederichs submitted his final report to the BSU on 10 November 2016 after an extensive review. A moderately edited summary of its contents (including the photographs and graphics enclosed with the opinion) follows in italics. The structure of the opinion is retained for the sake of clarity.

#### **3.3.14.2 Opinion of Professor Diederichs**

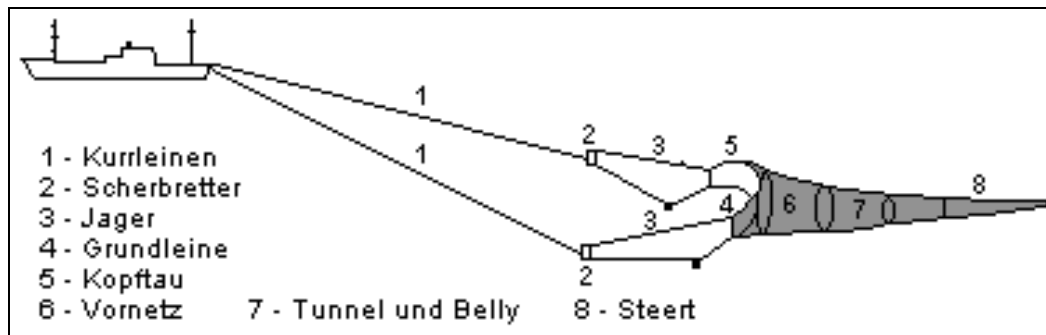
##### *"I. Brief descriptions*

###### *1.1 Ship with fishing equipment/technology*

*The Ship Safety Division (BG Verkehr) has approved the FV CONDOR as a side trawler for coastal fishing. At the request of the operator, an unscheduled D Survey<sup>33</sup> was carried out in August 2007 when the propulsion motor was exchanged. The following scheduled D Survey was carried out on 17 February 2015 and valid until 8 August 2019. The CONDOR was used for trawling.*

---

<sup>33</sup> Note by the BSU: D Survey = A standardised comprehensive survey of the accident prevention and ship safety installations and appliances (here the engine, in particular) carried out by the Ship Safety Division (BG Verkehr) every two years through a technical inspector or a surveyor from a recognised classification society.



**Figure 86: Drawing of the fishing equipment (trawling)**

The fishing vessel is equipped with two net-winding winches, a trawl winch and her so-called bobby winch for this purpose. All the winches are positioned on deck. The trawl is unwound from the net-winding winch and the trawl warps are attached to the trawl boards when fishing. The trawl warps are routed to the net via rollers on two gallows on the starboard side. After the trawl is paid out, it is pulled through the water with the trawl warps at a speed of 3-4 kts.

The following steps are required to haul in the net:

- (1) the trawl warps are wound in until the trawl boards are hanging from the gallows;
- (2) the net is wound in using the net-winding winch until the entire catch has collected in the codend and tunnel and is floating in the water next to the ship;
- (3) the hoisting rope of the bobby winch is attached to the halving becket (securing rings on the net between tunnel and codend);
- (4) the filled codend is then lifted out of the water using the bobby winch, positioned above the fish crates (hurdles) on deck, and emptied into it.

### 1.2 Engine

The engine is an off-the-shelf MAN D2876 diesel engine. The engine power has been restricted to 206 kW at 1,800 rpm in accordance with the provisions for trawlers. The documents from the Ship Safety Division (BG Verkehr) do not show which measures were taken to implement the restriction, however.

### 1.3 Fuel and lubricants system

The fuel system consists of four storage tanks with a capacity of about 4,000 litres. These are located on both sides of the engine room about 1.8 m above the engine. Due to the difference in height, static pressure causes the fuel to flow to the booster pump (gravity system).

The fuel booster pump is driven by the engine directly. When the engine is running, this pump feeds the fuel from the storage tanks to the engine's injection pump at increased pressure. Since the pump flow rate is usually greater than the engine consumption, the excess fuel is returned to the suction side of the pump (pressure control valve for constant pressure). When the engine is stationary, the entire fuel system can be vented with the hand pump.

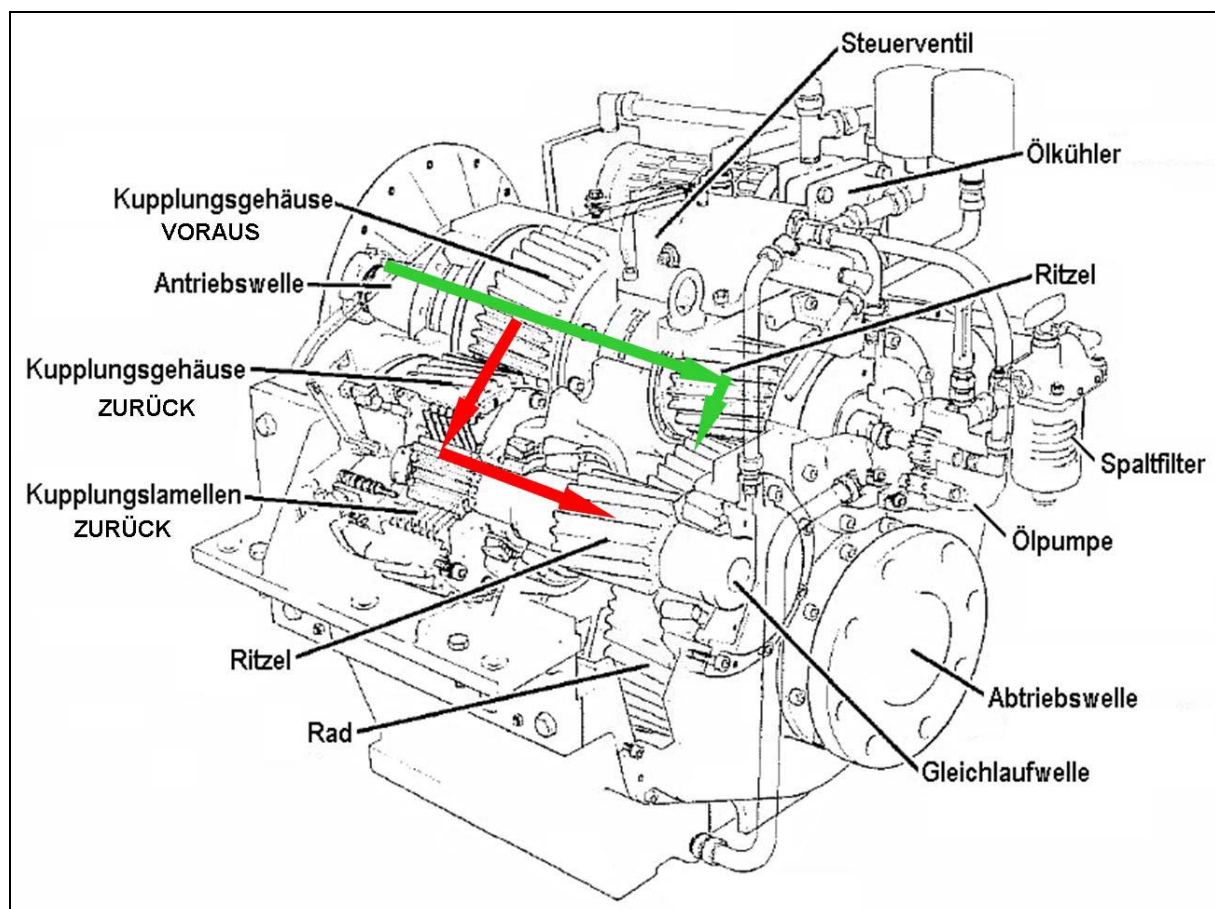
The cooling water system consists of three closed circuits: the high-temperature circuit (HT circuit), the low-temperature circuit (LT circuit) and the untreated water circuit. The HT circuit only helps to cool the engine. The heat absorbed by the cooling water is transferred to the untreated water in the HT cooler. The LT circuit is used for re-cooling the HT cooling water as well as for cooling the scavenge air, the engine lubricating oil, the transmission oil and the hydraulic oil. The heat absorbed by the LT cooling water is also transferred to the untreated

water. The total heat energy supplied to the untreated water is then transferred to the seawater via the external cooler mounted on the side of the keel.

#### 1.4 Transmission unit

The propeller is driven by a reverse reduction gear (Reintjes WAF 240, reduction ratio  $i = 3.905 : 1$ ). The propeller shaft's direction of rotation is selected by 'closing' the respective hydraulic coupling. The engine and propeller shaft rotate in opposite directions when moving ahead (green path) and in the same direction when moving astern (red path). The couplings are closed and opened via a 4/3 control valve.

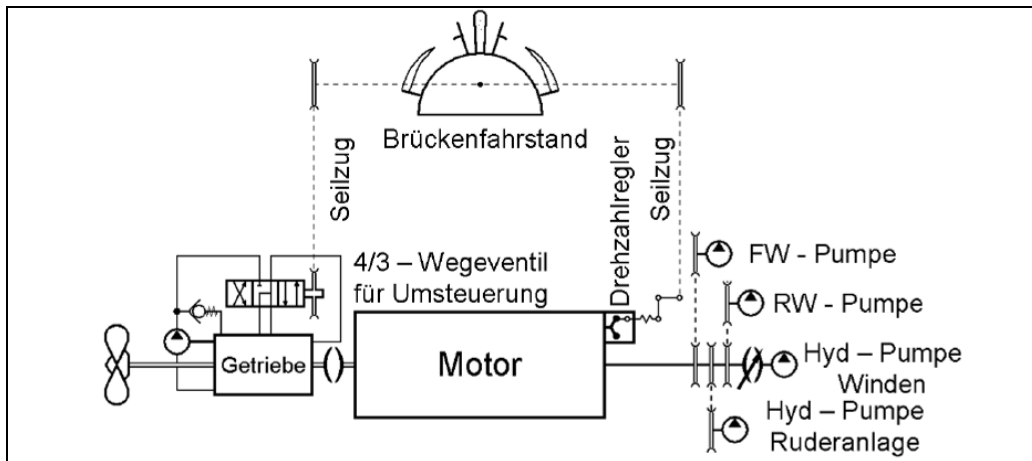
The oil required to lubricate the bearings and operate the hydraulic couplings is fed by an attached lubricating oil pump. This draws the oil from the gear housing and pushes it via the edge filter and oil cooler to the bearings and the pressure oil connection 'P' of the 4/3-way control valve for the couplings.



**Figure 87: Sectional view of the reversing gear unit**

#### 1.5 Engine and transmission control system

The engine and transmission are operated via a shared control lever at the bridge operator stand.

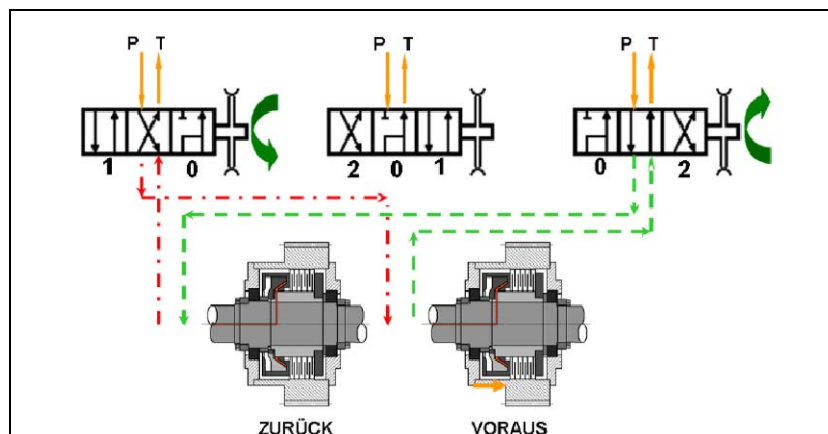


**Figure 88: Diagram of engine and transmission control system**

The 'filling lever' on the engine's injection pump and the 4/3 control valve of the transmission are connected to the control lever at the bridge operator stand by wire cable. Prior to starting the engine, the control lever is moved into the middle position marked stop. In this position, both multi-plate couplings of the transmission are open and the engine's injection pump is in the idle position.

When the control lever is moved to the ahead or the astern position until the idling end mark is reached, the control sliders for the 4/3-way valve are turned to the position 0/1/2 (ahead) or position 1/2/0 (astern) by means of the connecting cable. This connects the feed line of the respective multi-plate coupling to the pressure oil connection 'P' and closes the respective coupling. At the same time

- (1) the feed line to the pressure cylinder of the other multi-plate coupling is connected to the return line 'T' and
- (2) the idling lever on the engine's injection pump is activated and via a tension spring also the idling lever; this increases the starting speed (about 650-700 rpm) to the 'coupling speed' (about 850-900 rpm).



**Figure 89: Diagram of the reversing gear**

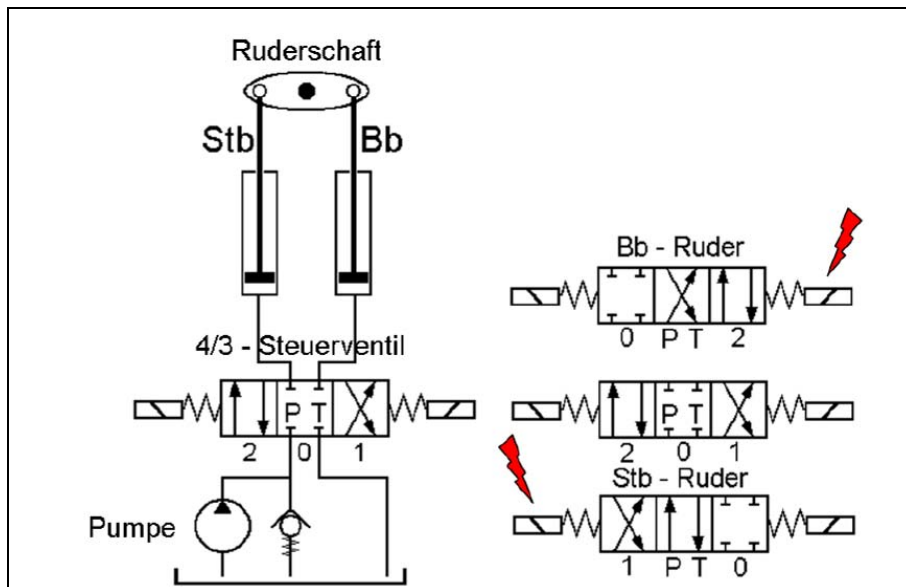
In the control lever's middle position marked stop, the 4/3-way control valve is centred in the middle position – position 2/0/1 – by springs and the feed lines of both multi-plate couplings are connected to the return line 'T'.

The centrifugal governor installed in the injection pump only guarantees the idling speed and limits the maximum speed. Between these two limits, the engine speed is only directly influenced by the filling lever. The design ensures that the amount of fuel to be injected changes proportionally to the transmission ratio of the filling lever.

To prevent the engine from stalling during engagement despite an increase in engine speed, the feed lines to the hydraulic couplings have 'storage volumes', which delay engaging but not disengaging. The propeller shaft is designed to rotate freely when both multi-plate couplings are open. This is the case when the engine is at a standstill (no control oil) and when the engine is rotating in the control lever's middle position.

#### 1.4 Steering gear

The vessel is equipped with hydraulic steering gear. The non-controllable hydraulic pump driven by the diesel engine draws the oil from the holding tank and transfers it into a ring line. The pressure in the ring line is kept constant by a spring-loaded valve.

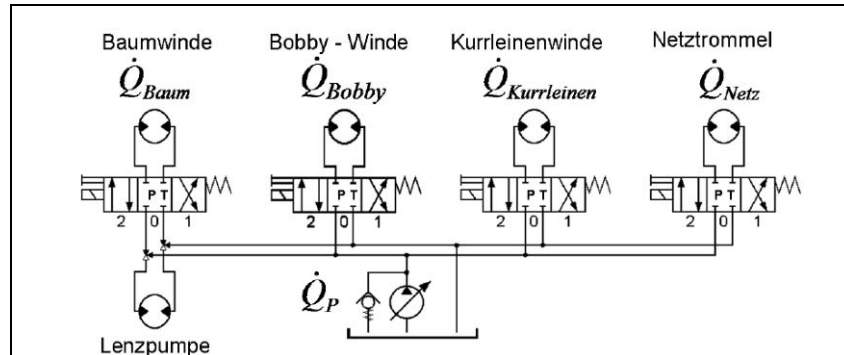


**Figure 90: Diagram of the steering gear**

The 4/3-way control valve is centred in the middle position 2/0/1 by springs. In this position, the feed lines of the two single-acting plungers are closed and the rudderstock fixed in the current position. Operating the steering wheel causes one of the solenoids to be excited electrically and the 4/3-way valve is activated. Depending on the excited solenoid, the control valve assumes position 0/1/2 or 1/2/0 and the associated hydraulic cylinder is connected to the pressure oil connection 'P'. At the same time, the other hydraulic cylinder is connected to the return flow line 'T'. The rudderstock is turned for as long as the respective solenoid is excited. Switching off the excitation current causes the control valve to assume the middle position (centred) through spring force, the rudderstock's rotary movement is stopped and 'fixed' in the current position (time-dependent or manual rudder control) by the closing of both feed lines to the pressure cylinders of the rudderstock. The current rudder position is transmitted hydraulically to an indicator on the bridge.

### 1.7 Winches

The pressure oil required to drive the winches is fed by a non-controllable hydraulic pump. This is driven directly by the engine via a transmission gear. A clutch coupling is located between the engine and transmission gear so that the pump can be switched off for cruising speed.



**Figure 91: Diagram of the winch control system**

The hydraulic pump draws the oil from the holding tank and transfers it via the feed line to the 4/3-way control valves for the winches on the vessel's deck. The pressure in this feed line is controlled by a spring-loaded valve (constant pressure valve). The surplus from the constant pressure valve and the return flow of the 4/3-way control valves flows back into the atmospherically ventilated holding tank.

The control valves can be operated manually (deck operator stand) or electromagnetically (lever in the bridge console). By operating a control valve, the feed line 'P' and the return flow 'T' are connected to the propulsion motor of the respective winch (net-winding winch, trawl winch, mast winch, boom winch).

Rather than the boom winch, the bilge pump can also be driven hydraulically instead. To this end, the oil flow must be diverted to the feed and return lines via changeover valves.

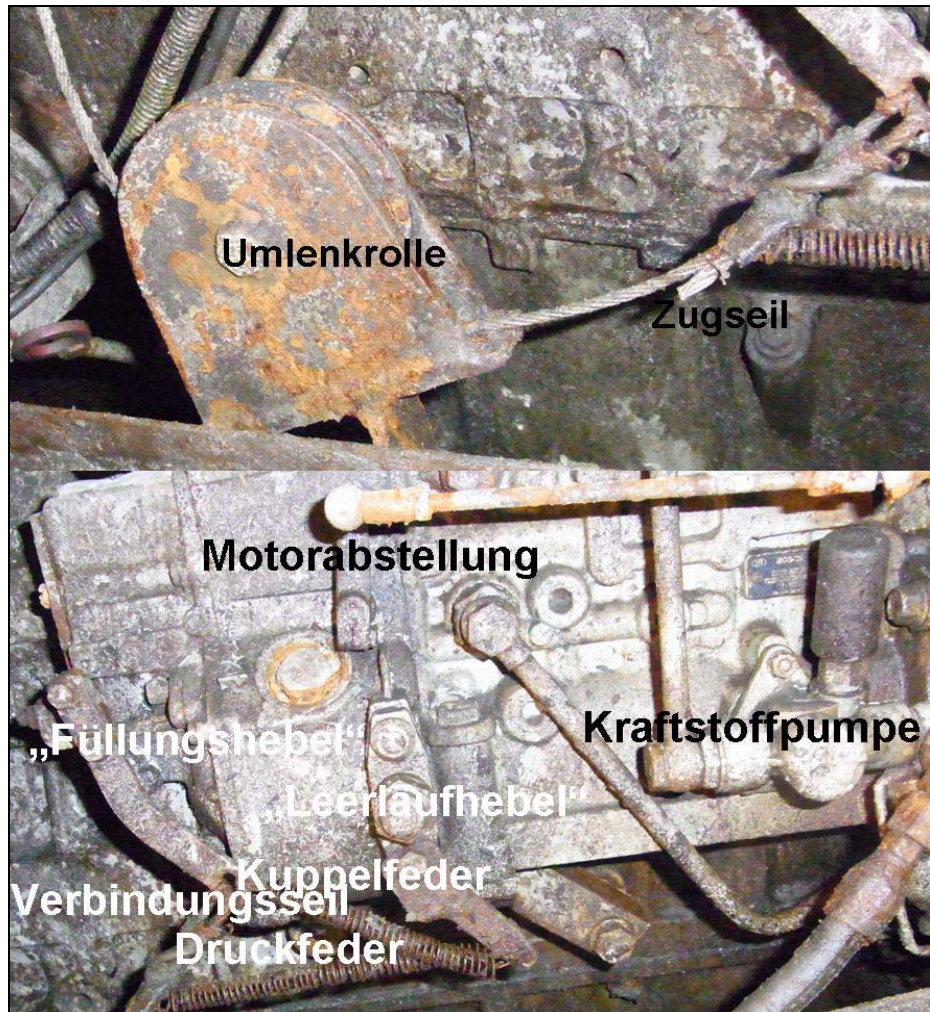
## II. Diagnoses

To carry out the BSU's investigation order, visual inspections (diagnoses) were carried out on the vessel on two dates (3 May 2016 and 25 May 2016).

### II.1 Engine

Although the piping and engine were dirty and partly corroded, no mechanical damage or other anomalies indicative of a failure could be found.

The traction cable for the engine control system was not torn off and still firmly connected to the engine's injection pump. The guide pulley and the filling and idling lever on the injection pump were movable.



**Figure 92: Traction cable with pulley and injection pump**

*The lever to stop the engine was still in the operating position. Accordingly, the engine was not switched off from the bridge before the accident.*

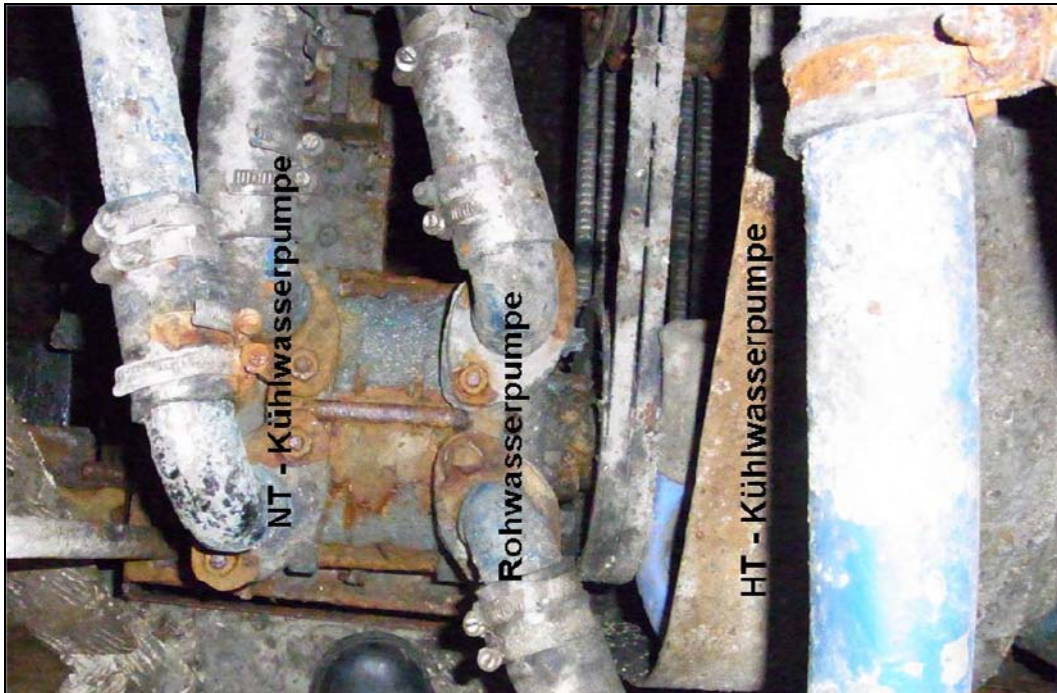
*The cable for the engine control was not pulled tight. Since the speed governor pulls the traction cable tight in normal operation when the engine is running, a slack traction cable is not indicative of engine control failure when the engine is stationary.*

## *II.2 Fuel and lubricants system*

*The fuel system was not opened for reasons of safety (danger of leakage). This means that it was not possible to determine the composition of the contents nor the filling level in the fuel tanks. The fuel lines to the engine were open.*

*The inspection glass of the filter in front of the booster pump revealed cloudiness. This is indicative of a mixture of seawater and fuel. However, it can be assumed that the engine was supplied with sufficient fuel until standstill.*

*The cooling water pipes and pumps exhibited considerable corrosion in places but no mechanical damage or other anomalies indicative of failure or leakage could be found. The pump V-belt drives were complete and tensioned.*



**Figure 93: Cooling water pumps and piping**

*II.3 Transmission unit*

*Neither the piping nor the transmission unit exhibited mechanical damage or other anomalies indicative of a failure.*

*The traction cable for the transmission control was not torn off and still firmly attached to the drive roller of the control valve on the transmission motor.*

*The smoothness of the transmission unit could not be checked, as corrosion in the engine prevented it from rotating.*



**Figure 94: Transmission block with control unit**

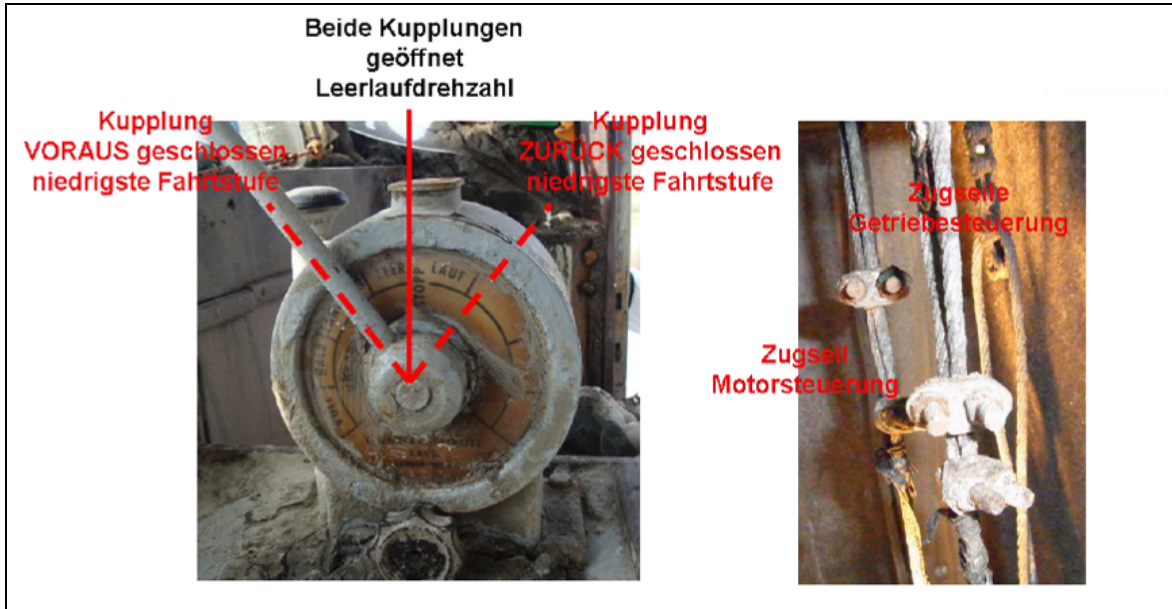


Ref.: 44/16

The 4/3-way control valve's drive wheel was turned to the left and in the 'ahead coupling closed' position.

#### II.4 Engine and transmission control

The control lever at the bridge operator stand was in the 'coupling ahead closed and lowest speed' position (coupling speed).

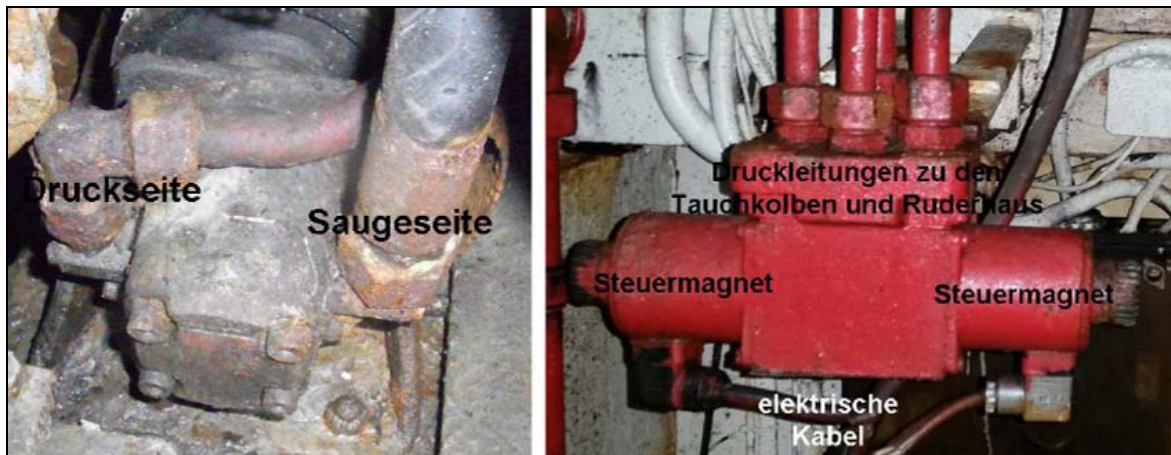


**Figure 95: Control system in the bridge console**

The traction cables for the engine and transmission control were firmly connected to the control lever at the bridge operator stand. The ends of the two cables for the transmission control exhibited a difference in height of about 4 cm. This corresponds approximately to the distance on the circumference of the wheel at the 4/3-way control valve on the transmission unit.

#### II.5 Steering gear

The piping and the pump exhibited only minor corrosion and were in relatively good condition. No mechanical damage or other anomalies indicative of a failure or leakage could be found. The pump's V-belt drive was complete and the belts tensioned.



**Figure 96: Hydraulic pump and steering gear control valve**

Ref.: 44/16

The electrical cables for the control solenoids were undamaged and the connections exhibited no leaks or other anomalies indicative of a short circuit or other faults.

The port side plunger was extended to about 90%, corresponding to the starboard position of the rudder blade.

#### II.4 Winches

The hydraulic pump and the piping were corroded but no mechanical damage or other anomalies indicative of a pump failure or pipe leakage could be found.

The clutch coupling to the transmission gear for the hydraulic pump was engaged. The shift lever moved easily and the coupling engaged and disengaged audibly and perceptibly.



Figure 97: Winch hydraulic pump with drive

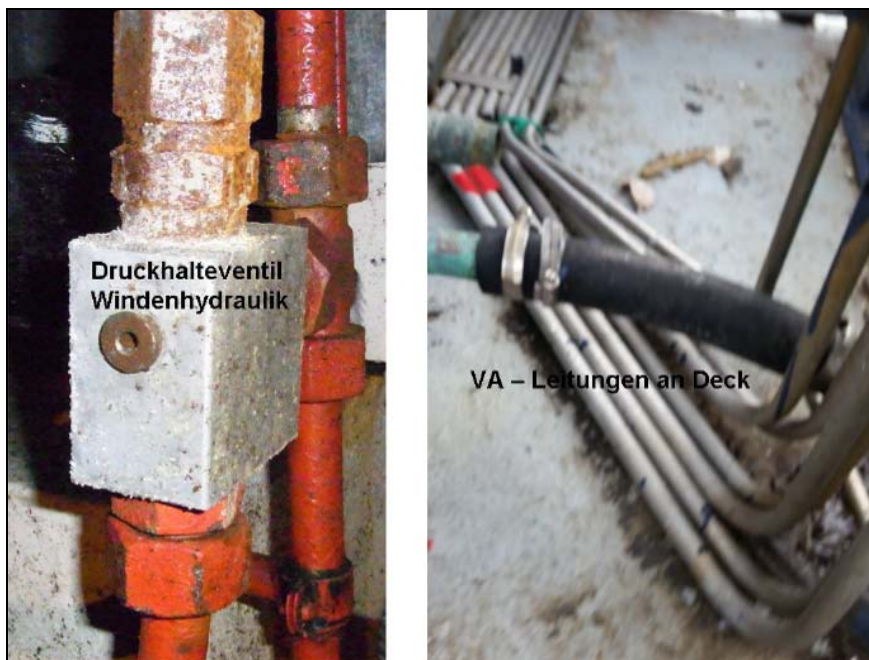


Figure 98: Pressure control valve and hydraulic lines on deck

The piping in the engine room was made of steel and on deck mainly of stainless steel. Although the pressure control valve exhibited heavy corrosion on the bolting, no mechanical damage or other anomalies indicative of leakage or valve failure could be found.



**Figure 99: Winch control position on deck**

The 4/3-way winch control valves positioned on deck exhibited heavy corrosion but no mechanical damage or other anomalies on the surface of the control sliders indicative of a valve failure could be found. The valves moved easily and after deflection were centred again perfectly to the middle position by the springs.



**Figure 100: 4/3-way valve surface for the trawl winch**

The toggle switches in the wheelhouse for the electrical control of the 4/3-way winch valves exhibited corrosion on the plugs as a result of prolonged exposure to seawater. Corrosion caused a cable to break off during the electrical test of the switches.



**Figure 101: Electrical winch control**

The distributor box at the deck operator stand was dry and no traces of seawater could be found. All switches and cable connections were electrically tested (resistance test with 600 V crank inductor). All contacts were electroconductive. Taking into account the effects of the seawater, the cable insulation values were satisfactory.



**Figure 102: Position of the changeover valves in the net-winding winch lines**

The 3-way changeover valves in the feed and return lines connected the net-winding winch to the 4/3-way control valves. The feed and return lines to the bilge pump were closed.

The piping to the trawl winch, bobby winch and loading winch on the port side tore during the salvage operation but the connections on the winch motors were faultless. No mechanical damage or other anomalies indicative of leaks or malfunctions of the connections or winch motors could be found.



**Figure 103: Destroyed hoses and pipes on the port railing**

### III. Summary

The instructions were to examine and assess possible operating conditions of the propulsion system (engine in operation, transmission engaged) and of the winches (hydraulic pump engaged or disengaged), as well as technical failures (engine/transmission/winch control) immediately before the accident.

Documents of comparable fishing vessel types exhibit a maximum ship speed of about 8 kts at 206 kW engine power and 1,800 rpm. With sufficient approximation, these comparative data produce the following table:

Motorleistung [kW]	Motordrehzahl [1/min]	Schiffsgeschwindigkeit [kn]
206	1800	8,0
103	1429	6,4
52	1134	5,0
26/18	900/800	4,0/3,6

The lowest engine speed when the transmission unit is engaged is about 800-900 rpm, corresponding to a ship speed of 3.6-4.0 kts.

Neither the engine nor the remote control exhibited mechanical damage (control cable breakage) or other anomalies (low fuel level) indicative of engine failure.

In conjunction with the analyses of VTS Travemünde, the engine was operated with transmission coupled to ahead and at the lowest rate of speed at the presumed time of the accident (103605).

Neither the hydraulic pump, the entire control system nor the steering gear itself exhibited mechanical damage (control cable breakage) or other anomalies (low fuel level) indicative of steering gear failure.

*Neither the hydraulic pump, the winch control system nor the piping with the winch motors exhibited mechanical damage or other anomalies (misconnection due to electrical leakage currents) indicative of a failure of the system in general.*

*A failure of the bobby winch did not make it impossible to set down the codend, which was most likely still hanging in the bobby winch."*

### **3.3.15 Assessment of the FV CONDOR's hydrostatic properties**

#### **3.3.15.1 Preliminary remarks**

Due to a lack of other possible causes of the accident, after the fishing vessel was salvaged, the evidence increasingly pointed to stability problems causing her to founder.

The BSU commissioned the expert Dipl.-Ing. Jan Hatecke with an assessment of the FV CONDOR's hydrostatic properties. The BSU provided the expert with all the background information concerning the vessel and course of her voyage on the day of the accident and various other items of information ascertained by the BSU independently or obtained from other files (WSP's investigation file, files of Ship Safety Division (BG Verkehr) and of the BSH) for his extensive review.

In addition to the aforementioned sources of information, the expert's opinion was based mainly on the findings, measurement results and mass determinations made during on-site visits. In addition, the BSU and the expert liaised closely over several months by phone, email and in personal discussions.

To verify the findings and calculations he had made, the expert intended to carry out an in-service inclining test. This involves assessing the stability conditions by means of a practical procedure in which an upright ship floating in the water is exposed to a defined heeling moment and the ensuing heel is measured. The heel makes it possible to determine the initial metacentric height of the ship. The moment is generated either by shifting, loading or discharging a known mass.

However, WSA Stralsund, which is responsible for traffic safety in the waters adjacent to CONDOR's storage site, expressed safety concerns with regard to lowering the fishing vessel into the water temporarily, which was necessary for the test. The WSA feared that the fishing vessel would break apart and then obstruct transiting shipping. For this reason, it prohibited execution of the inclining test.

### 3.3.15.2 Opinion of Dipl.-Ing. Jan Hatecke

An edited summary of the main parts of the opinion of Dipl.-Ing. Hatecke, which was submitted to the BSU on 1 December 2016, follows in italics. The structure of the opinion chosen by the expert is retained for the sake of clarity.

#### **"A.2. Survey of the wreck of the FV CONDOR after she was salvaged**

*The survey of the raised wreck starts at about 1200 on 8 March 2016 in the presence of WSP and BSU investigators with the following findings, which influence the assessment of the cause of the accident:*

- *as already noted in the salvage report, no underwater leakage was found on the fishing vessel. During the salvage operation, water could be pumped out without new water replacing it;*
- *damage to the starboard side of the shell plating and port side in the area of the forward mast's base was caused by salvage slings;*
- *the structure of the visible wood planking with GRP coating, the equipment on deck and the deckhouse leaves a positive impression;*
- *both masts are severely damaged due to the salvage operation;*
- *the fish hurdles on deck, the bulwark with openings, the tanks in the engine room and the fresh water tank in the fore section are measured;*
- *the fish hold is inspected. It is clean and without fish. There is nothing to suggest it had been used to store fish on the day of the accident.*



**Figure 104: FV CONDOR's fish hold (not used on the day of the accident)**

Ref.: 44/16

- two tank openings on the starboard side of the main deck next to the superstructure are open. One tank opening cap is lying on deck. The salvage company sealed both openings temporarily during the salvage operation;



**Figure 105: Tank opening on the starboard side**

- bolting ( $\varnothing$  350 mm) between the deck and fish hold is absent;



**Figure 106: Absent bolting between the deck and fish hold**

- the inlet air flap on the port side of the lower forward edge of the superstructure is not closed;



**Figure 107: Inlet air flap at forward edge of wheelhouse**



Ref.: 44/16

- the rudder is turned 37° to starboard;



**Figure 108: Position of the rudder blade at the time of the accident**

- the fish chute is absent. The DENEK discovered it 25 m south of the wreck while searching for the vessel;



**Figure 109: Usual position of the fish chute on an older photograph**

- two washboards for freeing port openings on the port side are missing;



**Figure 110: Freeing port openings on the port side**

- the door to the front cabin is open;

Ref.: 44/16

- the wheelhouse doors (starboard and port side) and windows are closed;
- the aft door of the wheelhouse is open;
- the fish hold hatch is closed but not secured.

Mainly filled with cod, the net's situation immediately after the salvage operation is that the net's codend is hanging in the bobby runner about 0.30 m above deck still closed and filled with fish. A large amount of cod is also found in the remaining part of the net, which is lying on the net drum during the salvage operation. The salvage company cut the nets open.



**Figure 111: Net's codend filled with fish immediately after the fishing vessel was salvaged**

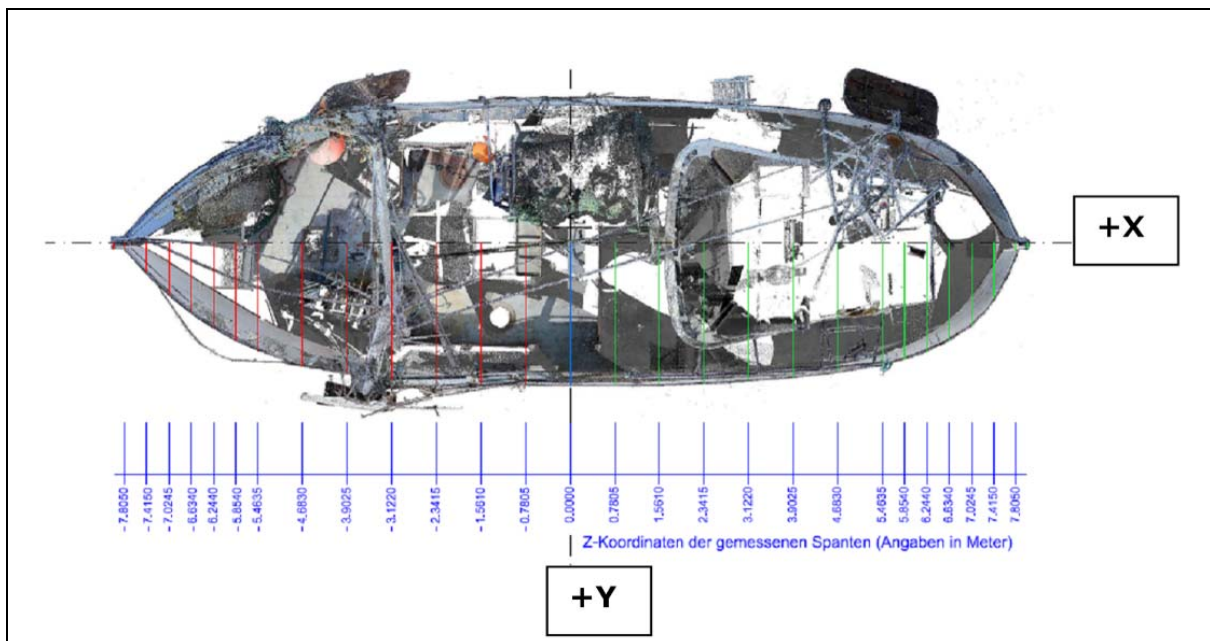
### **A.3. Scanning the shell plating contour of the FV CONDOR**

The raised wreck of the FV CONDOR was scanned by staff of LKA Hamburg on 15 March 2016 as part of administrative assistance for the BSU at the Warnemünde/Hohe Düne site using 3D laser technology. This means that the raised fishing vessel's external particulars are recorded precisely. This survey was used to determine the contour of the fishing vessel's shell plating. The survey experts at LKA Hamburg prepared these data points so that they can be used as input for the hydrostatic software. This enables the volume to be recorded precisely as a basis for the various stability calculations of the fishing vessel.

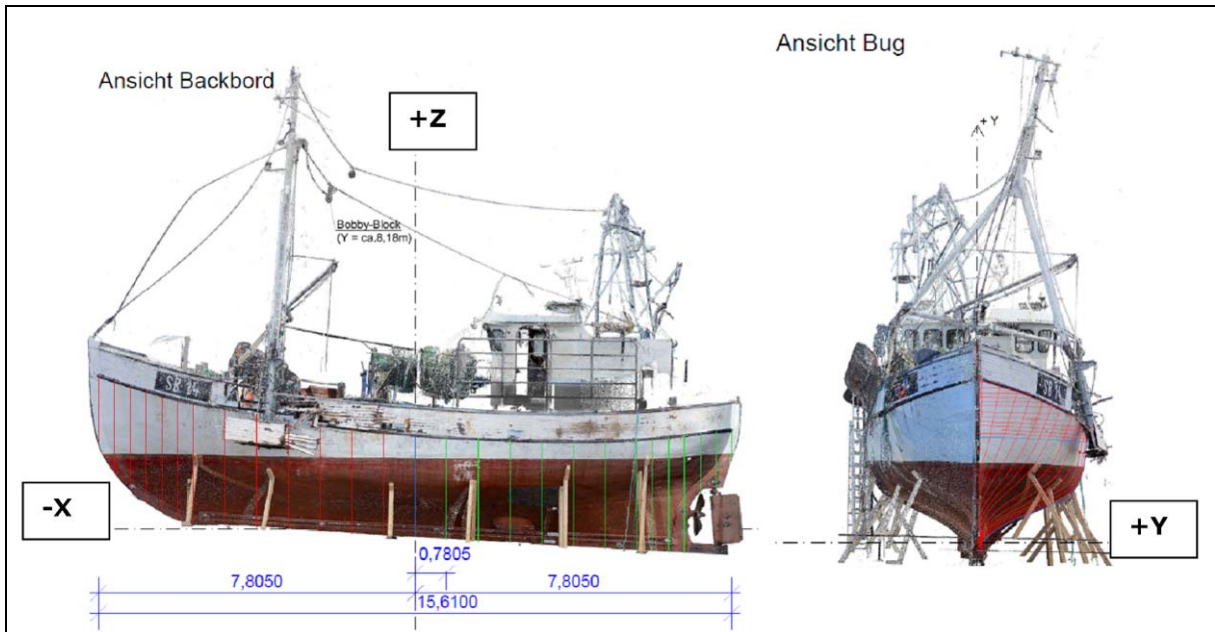


**Figure 112: 3D laser scan of the FV CONDOR by LKA Hamburg**

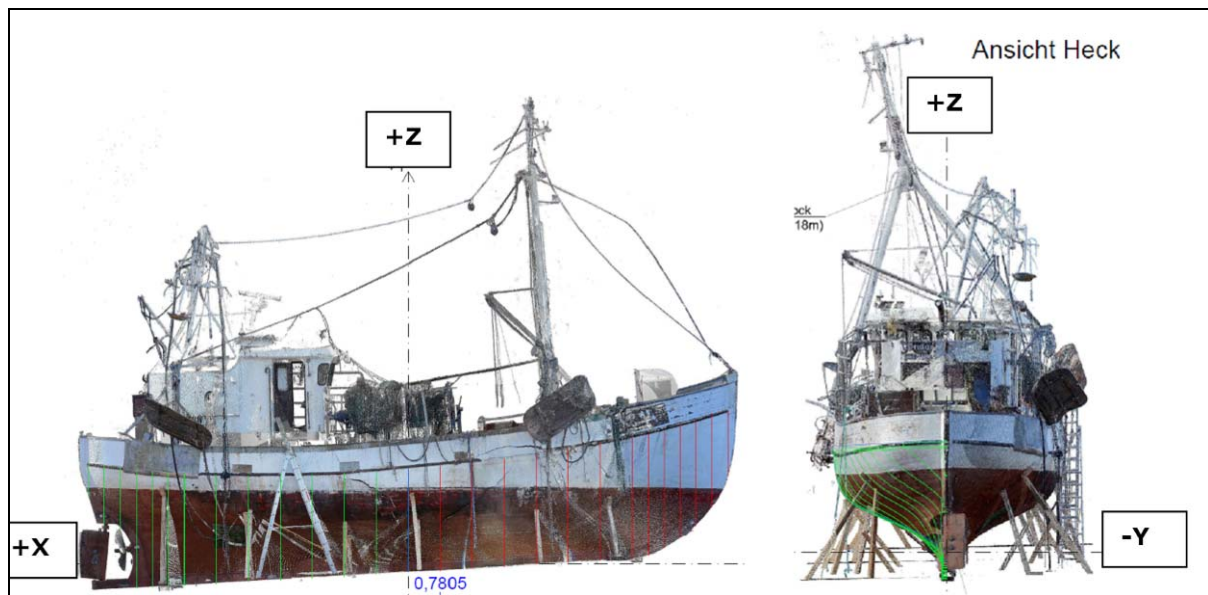
The fishing vessel's frame coordinates were defined during the analysis of the shell plating contour. Here Frame 0. was positioned halfway along the length. The x-coordinates are marked with plus values toward the stern and minus values toward the bow. The frames are placed vertically on the horizontal boot topping. The height as z-coordinate has the marking = 0. at this Frame 0. on the keel-rabbit intersection. The frame arrangement between the intersection points of the horizontal waterline is generated with the stem rabbet and sternpost. The result is 20 frame spacings of 0.7805 m each. Three intermediate frames are created in both the forward and the aft sections of the vessel to make it possible to display the contour very precisely. The length between perpendiculars ( $L_{pp}$ ) is therefore  $20 \times 0.7805 = 15.61 \text{ m}$ . The total length of the fishing vessel can be determined as about 16.10 m.



**Figure 113: Analysis of the scan process (top view)**



**Figure 114: Analysis of the scan process (port side from the bow)**



**Figure 115: Analysis of the scan process (starboard side from the stern)**

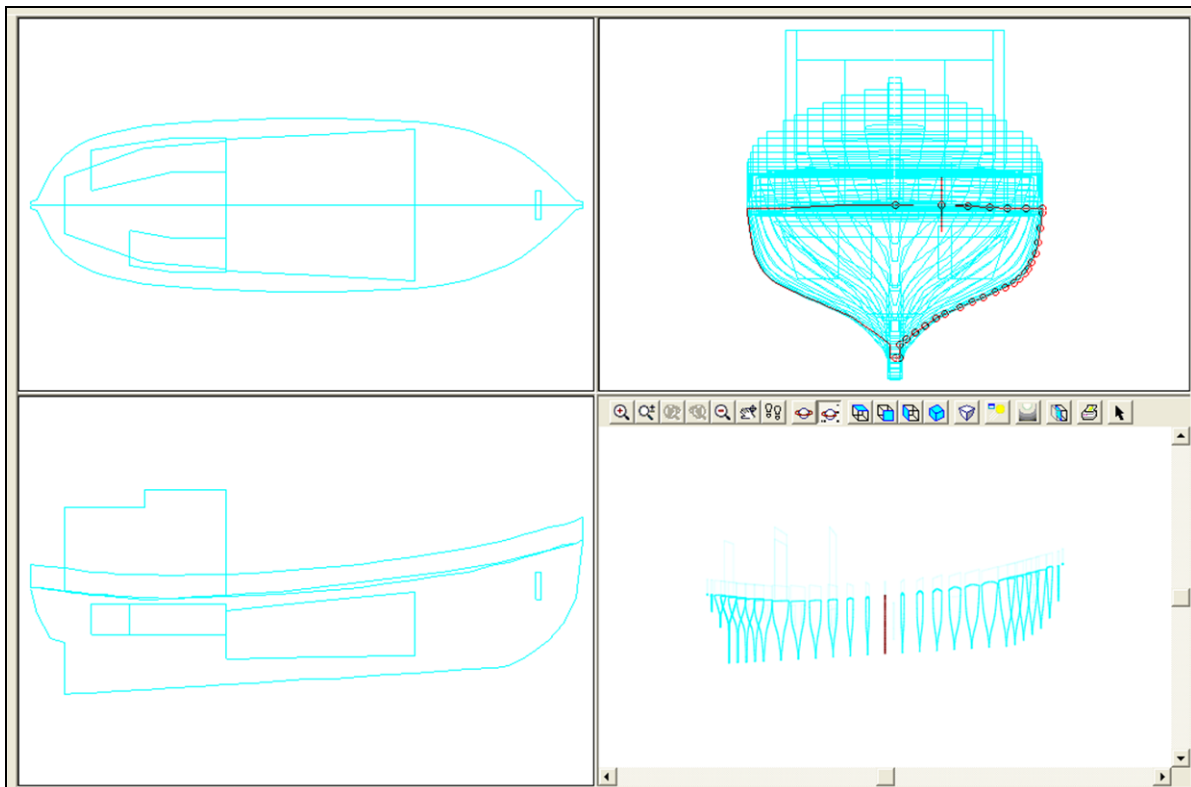
#### **A.4 Hydrostatic software**

The below hydrostatic calculations have been made using the AUTOHYDRO software (version 6.6.1.) from the company Autoship Systems Corporation in Canada. The necessary ship geometry of the fishing vessel's outer contour has been made using the software module MODELMAKER 6.1.1. with the X/Y/Z coordinates determined in section A.3.



**Figure 116: Information about the hydrostatic software used**

*In this context, the fuel tanks in the engine room and the forward fresh water tank have also been entered in the software. These can be populated with the corresponding filling levels in the calculations. The deckhouse has also been measured as an outer contour. For the detailed investigations, the bulwark and fish hold are measured as tanks.*



**Figure 117: MODELMAKER (the output program)**

## **A.5. Determination of the masses and centres of gravity at the time of the accident**

### **A.5.1 Determination of masses and centres of gravity 'EMPTY SHIP'**

Both the position of the centre of gravity and the mass 'EMPTY SHIP' are essential for the following hydrostatic calculations to determine the stability at the time of the accident. The data on centres of gravity available following a combined roll period and inclining test made in 2005<sup>34</sup> are not regarded as sound. It should be noted that the basis for determining the vertical centre of gravity of the mass is not clearly defined. There are no statements as to what hull shape data are used. In addition, subsequent conversions may have been made to the fishing vessel that are not included in the data from 2005.

#### **A.5.1.1 Determination of individual masses to calculate the total mass and centre of gravity 'EMPTY SHIP'**

To determine a meaningful and sound centre of gravity situation for the fishing vessel at the time of the accident, larger individual masses of the vessel are weighed. This weighing is carried out during the scrapping of the fishing vessel. The wreck of the fishing vessel is dismantled into individual masses on the grounds of the WSA's buoy yard in Warnemünde/Hohe Düne from 12 September 2016 (see **Fig. 118** by way of example).



**Figure 118: Weighing the entire superstructure, including toilet compartment and exhaust**

#### **General weighing data:**

<b>Date:</b>	20 September 2016
<b>Time:</b>	1230 to 1400
<b>Wind:</b>	NE 1
<b>Weather:</b>	20°, light clouds, occasional sunshine
<b>Scales:</b>	Type 450 traction dynamometer with radio transmitter and BHG, calibration certificate number 11316
<b>Measurement range:</b>	0-20 t in increments of 0.01 t

The expert measured the following large individual masses and applied centres of gravity to them. The masses of certain smaller objects were estimated as per the following list:

---

<sup>34</sup> Note by the BSU: See also the comments below in sections 4.4.2.1 f. and 5.1 of this investigation report.

No	Designation of individual mass	Determined mass (kg)
1	Forward mast with stays and ropes	1,000
2	Forward boom and small mast winch	90
3	Forward trawl board	240
4	Aft trawl board	220
5	Aft mast on superstructure with trawl board supports on starboard side	370
6	Superstructure complete with toilet compartment and exhaust (seam above coaming)	3,880
7	Net-winding winch complete with two nets	2,540
8	Forward trawl winch complete with ropes	1,680
9	Steel-reinforced sternpost/keel with rudder, propeller shaft, propeller, engine (altogether)	6,020
10	CO <sub>2</sub> cylinder	50
11	Tanks on port side without fluid	300
12	Tanks on starboard side without fluid	300
13	Concrete weight in keel	720
14	Batteries	200
15	Liferaft*	60
16	Pipes and engine room equipment (altogether)*	700
17	Bulwark*	1,100
18	Aft cabin equipment*	400
19	Forward cabin equipment with lines and ropes*	400
20	Deck equipment (altogether)*	800
21	Keel pipe cooling*	100
22	Towing line on observation deck*	100
23	Fish chute on port side*	150

\*Masses estimated rather than measured

#### **A.5.1.2 Determination of the mass 'EMPTY SHIP' of the FV CONDOR from the waterline plotted on the hull**

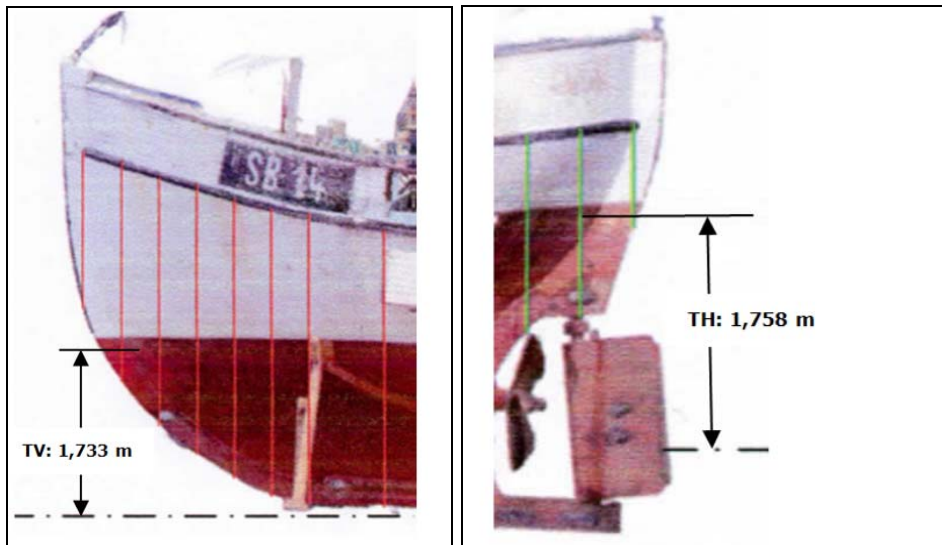
The scanned geometry of the fishing vessel was used to measure the actual floatation line. The corresponding draught values have been assigned to the forward and aft frames -7.415 and + 7.415.

For the determined draughts, the hydrostatic software AUTOHYDRO 6.1.1 has been used to determine the ship's mass at a water density of  $\rho=1.013^{35}$ . This mass is assumed as the empty ship mass for all subsequent calculations.

This produces the following draughts:

<b>Forward draught at Frame -7.415:</b>		<b>Aft draught at Frame +7.415:</b>	
FD port side:	1.732 m	AD port side:	1.761 m
FD starboard side:	1.734 m	AD starboard side:	1.755 m
<b>FD:</b>	<b>1.733 m</b>	<b>AD:</b>	<b>1.758 m</b>

<sup>35</sup> Note by the BSU: Information on water density in the Baltic Sea provided by the BSH.



**Figure 119: Findings of the draught determination**

*Based on the draughts found, it can be assumed that the ship was without a list at rest. The waterline is probably due to an extended period moored in port. It is assumed here that the tanks were 10% full. This proportion is deducted from the calculated volume. Otherwise, it is assumed that the measured floatation line represents the mass of the fishing vessel when ready for use with nets attached.*

Floating Status					
Draft FP	1.732 m	Heel	zero	GM(Solid)	2.756 m
Draft MS	1.746 m	Equil	No	F/S Corr.	0.002 m
Draft AP	1.759 m	Wind	Off	GM(Fluid)	2.754 m
Trim	aft 0.10 deg.	Wave	No	KMt	2.764 m
LCG	0.690a m	VCG	0.008 m	TPcm	0.57
Displacement	53.64 MT	WaterSpgr	1.013		
Loading Summary					
Item	Weight (MT)	LCG (m)	TCG (m)	VCG (m)	
Light Ship	53.30	0.674a	0.000	0.000	
Deadweight	0.34	3.312a	0.126p	1.225	
Displacement	53.64	0.690a	0.000	0.008	

**Figure 120: Overview of mass determination from the waterline<sup>36</sup>**

The following values have thus been determined:

**Mass 'EMPTY SHIP':**      **53,300 kg**  
**LCG:**                              **0.674 m**

**A.5.1.3 Determination of the VCG of the proportion 'Wood and remaining masses'**

*For the determination of the VCG of the proportion 'Wood and remaining masses', it is assumed that the vertical distribution of the masses is largely uniform. This means that the VCG of the volume is the same as that of the mass. To determine the centroid of the volume, the hull is completely submerged without bulwark or superstructure in the calculation.*

<sup>36</sup> Note by the BSU: LCG: Longitudinal centre of gravity of the mass. TCG: Transverse centre of gravity of the mass. VCG: Vertical centre of gravity of the mass.



Floating Status							
Draft FP	3.850 m	Heel	zero	GM(Solid)	1.655 m		
Draft MS	3.850 m	Equil	No	F/S Corr.	0.000 m		
Draft AP	3.850 m	Wind	Off	GM(Fluid)	1.655 m		
Trim	zero	Wave	No	KMt	1.655 m		
LCG	0.224f m	VCG	0.000 m	TPcm	und		
Displacement	99.50 MT	WaterSpgr	1.000				
Loading Summary							
Item	Weight (MT)	LCG (m)	TCG (m)	VCG (m)			
Light Ship	99.50	0.224f	0.000	0.000			
Displacement	99.50	0.224f	0.000	0.000			
Fixed Weight Status							
Item	Weight (MT)	LCG (m)	TCG (m)	VCG (m)			
LIGHT SHIP	99.50	0.224f	0.000	0.000			
<b>Total Weight:</b>	<b>99.50</b>	<b>0.224f</b>	<b>0.000</b>	<b>0.000</b>			
Displacer Status							
Item	Status	Spgr	Displ (MT)	LCB (m)	TCB (m)	VCB (m)	Eff /Perm
RUMPF	intact	1.000	99.50	0.224f	0.000	1.655	1.000
<b>SubTotals:</b>			<b>99.50</b>	<b>0.224f</b>	<b>0.000</b>	<b>1.655</b>	

**Figure 121: Overview of the VCG wood mass**

The following value has thus been determined:

VCG 'Wood and remaining masses': 1.655 m

#### A.5.1.4 List of the masses and determination of the VCG 'EMPTY SHIP' of the FV CONDOR

Zusammenstellung der Massen LEERES SCHIFF:

Nr.	Bezeichnung	Masse (kg)	LCG (m)	VCG (m)	TCG (m)
1	Mast vorne mit Stagen und Seilen	1000	-3,20	5,40	0,00
2	Baum vorne und kleine Winde vom Mast	90	-3,20	5,30	-0,30
3	Scherbrett vorne	240	-3,62	3,15	-2,60
4	Scherbrett hinten	220	5,60	2,90	-2,60
5	Mast hinten auf Aufbau mit Scherbretthalten an S.B.	370	5,70	5,10	-1,00
6	Aufbau komplett mit Toilettenraum u. Auspuff (Naht oberhalb des Sülls!)	3880	3,75	3,84	0,00
7	Netz-Winde kompl. mit zwei Netzen	2540	0,20	3,70	-1,25
8	Kurr-Winde vorne kompl. mit Seilen	1680	-3,90	3,55	1,10
9	Stahllarmierter Achterstevens/Kiel mit Ruder, Propellerwelle, Propeller, Motor (als ein Teil)	6020	4,80	0,53	0,00
10	CO2-Flasche	50	5,80	2,00	0,00
11	Tanks an B.B. ohne Flüssigkeit	300	4,21	1,65	1,17
12	Tanks an S.B. ohne Flüssigkeit	300	3,63	1,64	-1,27
13	Betongewicht im Kiel	720	-0,25	0,60	0,93
14	Batterien	200	2,40	2,00	-0,80
15	Rettungsinsel *	60	4,75	5,40	1,20
16	Rohre und Maschinenraum-Einrichtung pauschal *	700	4,00	1,70	0,00
17	Schanzkleid *	1100	0,00	2,75	0,00
18	Kajüt-Einrichtung hinten *	400	4,15	3,60	0,00
19	Kajüt-Einrichtung vorne mit Leinen und Tauwerk *	400	-4,35	1,70	0,00
20	Ausrüstung Deck pauschal *	800	-0,10	2,70	0,00
21	Kielrohrkühlung*	100	0,54	0,00	0,35
22	Schlepplaine auf Peildeck*	100	3,00	5,16	-1,00
23	Fischrutsche an B.B.-Seite*	150	-1,20	3,15	2,00
	<b>Ermittelte Einzelmassenmasse</b>	<b>21420</b>	<b>1,981</b>	<b>2,536</b>	<b>-0,100</b>
24	Anteil Holz und restliche Massen im Volumenhöhen­schwerpunkt des Kutters	31880	-0,204	1,655	0,067
	<b>Masse LEERES SCHIFF FK "CONDOR" ohne Tankfüllung</b>	<b>53300</b>	<b>0,674</b>	<b>2,009</b>	<b>0,000</b>

\* Nicht vermessen, sondern Massen angenommen

The mass 'EMPTY SHIP' has been determined above in section A.5.1.2 of the opinion with the corresponding longitudinal centre of mass. The mass for No 24 'Proportion of wood and remaining masses in the VCG of the fishing vessel's volume' has been calculated as the difference in mass of the individual masses determined to the masses in A.5.1.2 and the VCG of the mass in A.5.1.3.

It should be noted that the difference in the longitudinal centres of gravity in each calculation produces the following difference value:

LCG 'Proportion of wood and remaining masses' (A.5.1.4(24)):	-0.204 m
LCG = LCB (A.5.1.3):	-0.224 m
	<u>0.020 m</u>

This corresponds to a value of **0.13%** of the fishing vessel's **Lpp** and can be regarded as proof that the calculation used here to determine the masses and centres of gravity 'EMPTY SHIP' is plausible, conclusive and sound.

#### **A.5.2 Determination of the masses 'Fish at the time of the accident'**

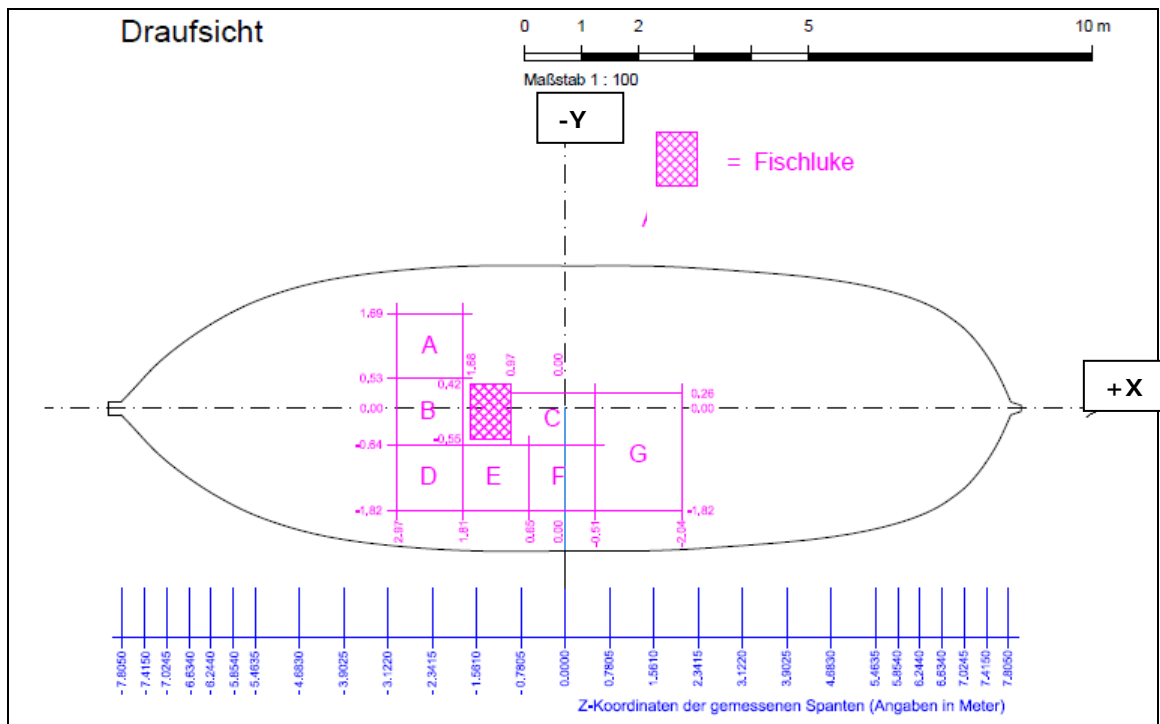
Based on the findings of the WSP, the BSU and information provided by the Burgstaaken fishermen's cooperative, it can be assumed that up to 120 fish crates were on board the fishing vessel at the time of the accident. An analysis of the above sources also indicates that at the time of the accident there were already about 3,000 kg of fish on the deck of the fishing vessel from three hauls. The catch from the fourth haul was still in the net. The surveys provide no indication that the fish hold below deck was used to store fish. If this was the case, fish, fish crates or soiling would have been found there after the salvage operation.

##### **A.5.2.1 Determination of the mass 'Fish on deck in crates'**

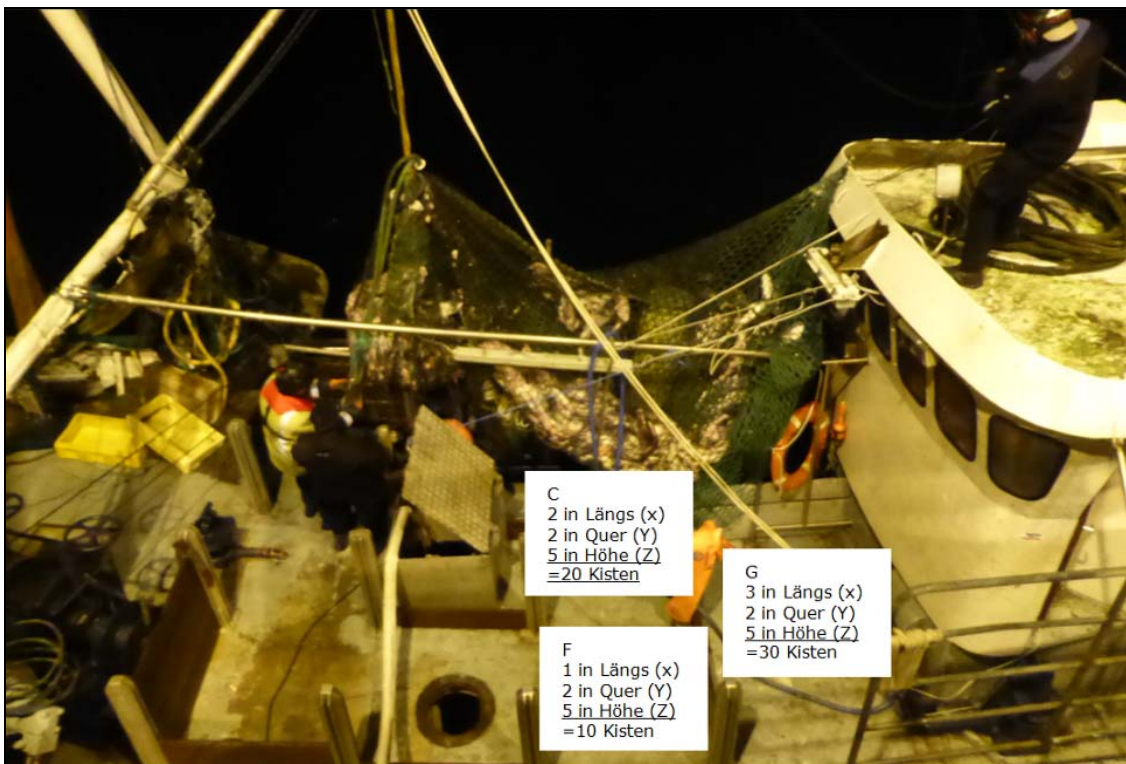
After consulting the expert from the Rendsburg Fishing School with regard to the usual working practices on board fishing vessels similar to the CONDOR, it is assumed that half of the catch situated on board had already been slaughtered and stored in fish crates at the time of the accident. The standardised fish crates have the dimensions 0.735 x 0.445 x 0.185 m (L x B x H) and an unladen weight of 4.2 kg. The average weight of fish contained is assumed to be 25 kg.

The positions of the filled fish crates are assumed as follows:

Nr.	Bezeichnung	Masse (kg)	LCG (m)	VCG (m)	TCG (m)
G	2 x 3 x 5 = 30 Kisten	876	1,27	2,81	1,08
C	2 x 2 x 5 = 20 Kisten	584	-0,23	2,99	0,19
F	1 x 2 x 5 = 10 Kisten	292	-0,07	2,86	1,23
	<b>Masse Fisch an Deck in Kisten</b>	<b>1752</b>	<b>0,547</b>	<b>2,878</b>	<b>0,808</b>



**Figure 122: Available stowage positions A-G for fish crates on the main deck of the fishing vessel**



**Figure 123: Presumed stowage positions of the filled fish crates on the day of the accident**

Ref.: 44/16

**A.5.2.2 Determination of the mass 'Empty fish crates'**

*It is assumed that the remaining 60 empty fish crates were stacked aft on the port side in a rack.*

**Mass:** 60 x 4.2 kg = 252 kg  
**LCG (X):** -3.25 m  
**VCG (Z):** 3.25 m  
**TCG (Y):** -2.00 m



**Figure 124: Stowage space for empty fish crates port side of the superstructure**

**A.5.2.3 Determination of the mass 'Fish on deck loose in hurdles'**

*The remainder of the non-slaughtered catch from the first three hauls was in the free hurdles on deck. The hurdles had a height of 0.96 m above deck. Accordingly, it involved the following*

*mass: 3,000 – (60 x 25) = 1,500 kg*

*The positions of the non-slaughtered fish in the hurdles are assumed as follows:*

Nr.	Bezeichnung	Masse (kg)	LCG (m)	VCG (m)	TCG (m)
D	Hocke B.B., vor Luke	500	-2,39	3,12	1,23
B	Hocke Mitte, vor Luke	500	-2,39	3,19	0,05
A	Hocke S.B., vor Luke	500	-2,39	3,15	-1,11
	<b>Masse Fisch an Deck in Hocken</b>	<b>1500</b>	<b>-1,260</b>	<b>3,153</b>	<b>0,057</b>

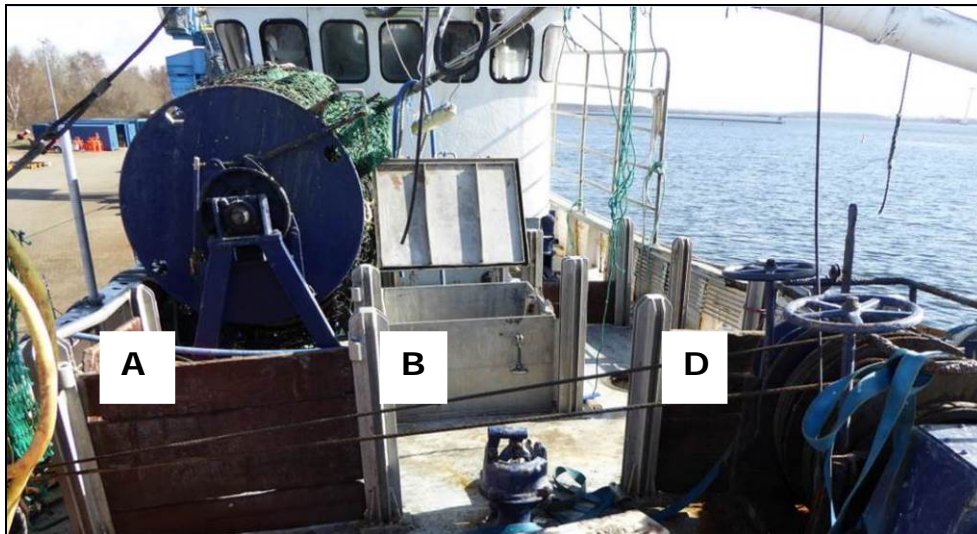


Figure 125: Storage spaces (hurdles) for the non-slaughtered catch on the main deck

**A.5.2.4 Determination of the mass 'Fish in codend'**

After the fishing vessel had reached the surface of the water during the salvage operation, it was found that the completely filled codend of the net hung in the bobby runner designed for this. The codend was pulled so high that it hung about 0.9 m above deck in the bobby tackle before the vessel foundered. The height evident from the photograph after the salvage operation must be corrected by the mast shifted downward on the port side. This height is conclusive because the codend could still be pulled over the bulwark.

The mass of the completely filled codend hanging in the bobby block is estimated at 750 kg after consulting the expert at the Rendsburg Fishing School. The coordinates of the bobby block have been assumed as the centre of gravity.

Mass of the filled codend:	750 kg
LCG (X):	-2.30 m
VCG (Z):	8.90 m
TCG (Y):	-0.50 m

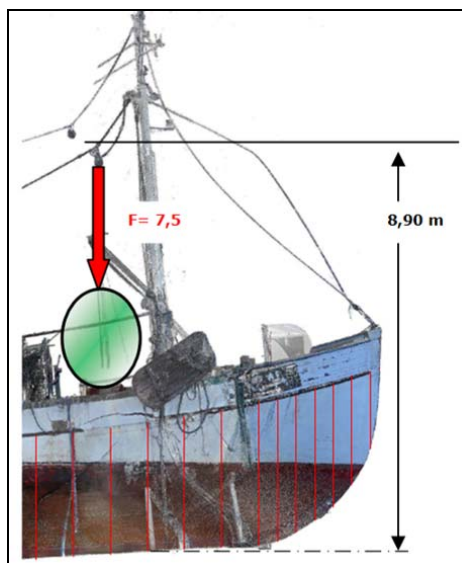


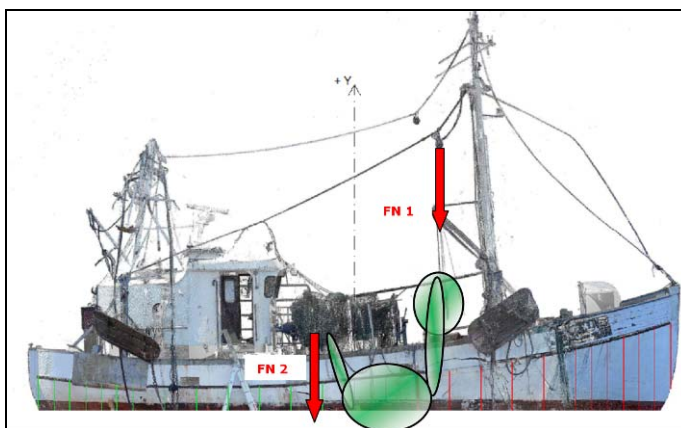
Figure 126: Determination of the centre of gravity 'Fish in codend'

**A.5.2.5 Determination of the mass 'Fish in net'**

In addition to the fish in the codend, there was also a large quantity of fish in the net. This is evident from the photographs taken during the salvage operation. This mass was defined at 1,000 kg minimum in consultation with the expert from the Rendsburg Fishing School. This mass of fish was also partly pulled up through the bobby runner together with the codend (Force FN1). The rear part of the net or its contents (Force FN2) acts on the aft winch drum. Measuring the length of the filled section of the net enables the conclusion that the filled net, fixed by the tractive force of the bobby winch and the fixed net-winding winch, hung tightly on the side of the fishing vessel's shell plating in the area of the waterline. It can be assumed that the largest part of the load acted in the bobby block when the vessel started to move ahead.



**Figure 127: Reconstruction of the codend's position**



Position	FN 1	FN 2
Masse (kg)	<b>800</b>	<b>200</b>
LCG (X) (m)	<b>-2,30</b>	<b>0,75</b>
VCG (Z) (m)	<b>8,90</b>	<b>3,70</b>
TCG (Y) (m)	<b>-0,50</b>	<b>-2,40</b>

**Figure 128: Components of force due to fish in the net**

### A.5.3 Determination of the mass 'Crew'

The skipper and a crew member were on board at the time of the accident. The skipper will have been in the wheelhouse and the crew member forward near the mast. The mass of these two people and their clothing is assumed to be 100 kg each.

Nr.	Bezeichnung	Masse (kg)	LCG (m)	VCG (m)	TCG (m)
1	Kapitän	100	3,00	4,10	-1,00
2	Besatzungsmitglied	100	-3,60	3,90	0,00
	<b>Crew</b>	<b>200</b>	<b>-0,300</b>	<b>4,000</b>	<b>-0,500</b>

### A.5.4 Determination of the masses and centres of gravity of supplies at the time of the accident

The investigations of the WSP and the BSU reveal that about 600 l of diesel was on board in the two tanks on the port and starboard sides at the time of the accident. This corresponds to a filling level of 18.1% of the measured tanks. This filling level of 18% has also been assumed for the forward fresh water tank. The fact that only a partial quantity of diesel was in the tanks is confirmed by the report on the disposal of the water/diesel mixture submitted by the waste management company. This results in the following masses and centres of gravity for the supplies in the tanks:

Tank Status						
DIESEL OIL (SpGr 0.870)						
Tank Name	Load (%)	Weight (MT)	LCG (m)	TCG (m)	VCG (m)	FSM
TKD.P	18.10%	0.35	3.830a	1.048p	1.268	
TKD.S	18.10%	0.25	3.396a	1.131s	1.252	
<b>Subtotals:</b>	<b>18.10%</b>	<b>0.60</b>	<b>3.649a</b>	<b>0.138p</b>	<b>1.261</b>	
FRESH WATER (SpGr 1.000)						
Tank Name	Load (%)	Weight (MT)	LCG (m)	TCG (m)	VCG (m)	FSM
TKW.C	18.00%	0.02	6.714f	0.010p	2.172	
<b>Subtotals:</b>	<b>18.00%</b>	<b>0.02</b>	<b>6.714f</b>	<b>0.010p</b>	<b>2.172</b>	
All Tanks						
	Load (%)	Weight (MT)	LCG (m)	TCG (m)	VCG (m)	FSM
<b>Totals:</b>	<b>18.10%</b>	<b>0.61</b>	<b>3.343a</b>	<b>0.135p</b>	<b>1.288</b>	

### A.5.5 List of the masses and centres of gravity at the time of the accident

The masses and centres of gravity determined under A.5 can be summarised as follows for the situation at the time of the accident:

Nr.	Bezeichnung	Masse (kg)	LCG (m)	VCG (m)	TCG (m)
1	Masse LEERES SCHIFF FK "CONDOR" ohne Tankfüllung	53300	0,674	2,009	0,000
2	Crew	200	-0,300	4,000	-0,500
3	Diesel Tank, B.B.-Seite	350	3,830	1,268	1,048
4	Diesel Tank, S.B.-Seite	250	3,397	1,252	-1,131
5	Frischwasser Tank, vorne	20	-3,343	2,172	0,010
6	Fisch an Deck in 60 Kisten	1752	0,547	2,878	0,808
7	Fisch lose an 'Deck in Hocken	1500	-1,260	3,153	0,057
8	Fisch im Steert	750	-2,300	8,900	-0,500
9	Fisch im Netz vorne (FN 1)	800	-2,300	8,900	-0,500
10	Fisch im Netz hinten (FN 2)	200	0,750	3,700	-2,400
11	Lose Fischkisten, 60 Stk.	252	3,250	3,250	2,000
	<b>Masse FK zum Unfallzeitpunkt</b>	<b>59374</b>	<b>0,580</b>	<b>2,254</b>	<b>0,012</b>

**B.1 Assessment of the FV CONDOR's stability at the time of the accident**

The accident involving the FV CONDOR on 6 February 2016 was caused by her **capsizing**.

The following causes can be ruled out:

1. foundering without capsizing, as no leakage or loss of watertight integrity was found below the waterline after the salvage operation;
2. remote control and engine failure;
3. the net catching on the bottom, as it was hanging tightly on the fishing vessel's shell plating.

For the following situation in the accident scenario, the hydrostatic properties of the wreck of the fishing vessel are assessed:

The CONDOR sails a turning circle toward the starboard side at a speed of 4.5 kts. At the same time, the rudder is turned hard to starboard. The following load conditions and assumptions are accounted for:

- 1,500 kg of fish on deck in hurdles;
- 1,752 kg of fish on deck in crates;
- 60 empty fish crates on deck;
- 750 kg of fish hanging in the codend with a VCG of 8.9 m;
- 1,000 kg of fish hanging in the net; 80% of this mass is also hanging on the bobby block;
- 600 l of diesel in the tanks;
- 20 l of fresh water;
- two crew members, each weighing 100 kg;
- the fish hold is assumed to be an empty space without mass;
- the density of the water at the scene of the accident is assumed to be  $\rho=1.013 \text{ t/m}^3$ ;
- the influence of the wind sea from the port side is not considered;
- the deckhouse is not measured as a floating body;
- the influence of the lateral wind of 15-20 kts from the port side can be neglected in the turning circle.

The following static assessment of the fishing vessel's hydrostatic properties at the time of the accident was calculated using the AUTOHYDRO software:

Fixed Weight Status						
Item	Weight (MT)	LCG (m)	TCG (m)	VCG (m)		
LIGHT SHIP	53.30	0.674a	0.000	2.009u		
CREW 2 PERSONS	0.20	0.300f	0.500s	4.000u		
FISCH IM NETZAN BOBBY FN 1	0.80	2.300f	0.500s	8.900u		
FISCH AN DECK IN KISTEN	1.75	0.547a	0.808p	2.878u		
FISCH AN DECK LOSE IN HOCKEN	1.50	1.260f	0.057p	3.153u		
FISCH IM NETZ AN WINDE FN 2	0.20	0.750a	2.400s	3.700u		
FISCH IM STEERT	0.75	2.300f	0.500s	8.900u		
FISCHKISTEN LEER AN DECK	0.25	3.250a	2.000p	3.250u		
<b>Total Fixed:</b>	<b>58.75</b>	<b>0.550a</b>	<b>0.011p</b>	<b>2.264u</b>		

Tank Status						
DIESEL OIL (SpGr 0.870)						
Tank Name	Load (%)	Weight (MT)	LCG (m)	TCG (m)	VCG (m)	FSM
TKD.P	18.10%	0.35	3.839a	1.046p	1.268	
TKD.S	18.10%	0.25	3.400a	1.131s	1.252	
<b>Subtotals:</b>	<b>18.10%</b>	<b>0.60</b>	<b>3.655a</b>	<b>0.138p</b>	<b>1.261</b>	



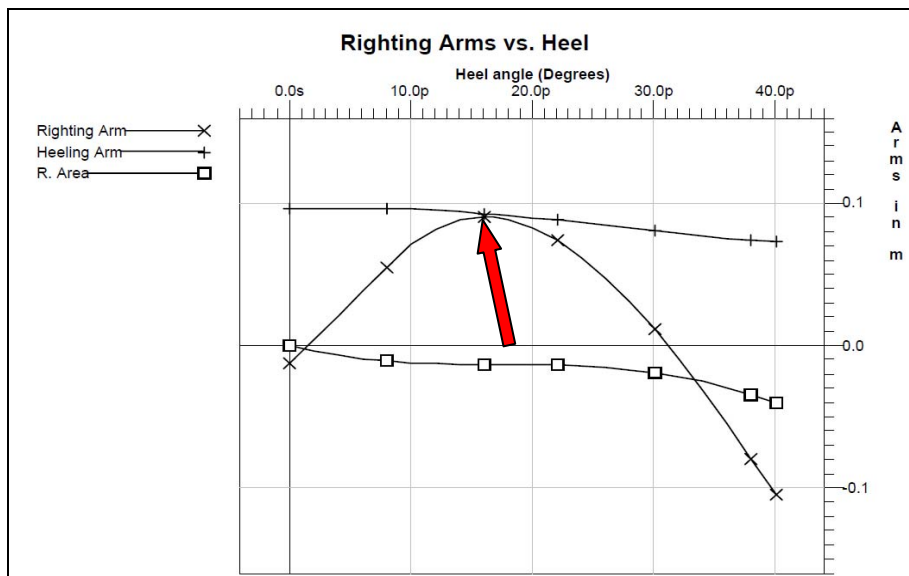
Floating Status					
Draft FP	1.894 m	Heel	port 1.45 deg.	GM(Solid)	0.487 m
Draft MS	1.848 m	Equil	No	F/S Corr.	0.002 m
Draft AP	1.803 m	Wind	Off	GM(Fluid)	0.485 m
Trim	fwd 0.32 deg.	Wave	No	KMt	2.740 m
LCG	0.579a m	VCG	2.254 m	TPcm	0.58
Displacement	59.37 MT	WaterSpgr	1.013		

**Figure 129: Stability calculation at the time of the accident**

Residual Righting Arms vs Heel Angle				
Heel Angle (deg)	Trim Angle (deg)	Origin Depth (m)	Residual Arm (m)	Area (m-Rad)
0.00	0.32f	1.849	-0.109	0.000
2.00p	0.32f	1.847	-0.092	-0.004
4.00p	0.33f	1.842	-0.075	-0.006
6.00p	0.33f	1.835	-0.058	-0.009
8.00p	0.34f	1.824	-0.041	-0.011
10.00p	0.34f	1.810	-0.025	-0.012
12.00p	0.31f	1.795	-0.013	-0.012
14.00p	0.26f	1.779	-0.005	-0.013
16.00p	0.18f	1.763	-0.002	-0.013
16.68p	0.15f	1.757	-0.002	-0.013
18.00p	0.08f	1.745	-0.003	-0.013
20.00p	0.04a	1.726	-0.007	-0.013
22.00p	0.17a	1.706	-0.014	-0.013
24.00p	0.31a	1.685	-0.025	-0.014
26.00p	0.47a	1.662	-0.037	-0.015
28.00p	0.62a	1.638	-0.052	-0.017
30.00p	0.79a	1.612	-0.069	-0.019
32.00p	0.96a	1.585	-0.088	-0.022
34.00p	1.14a	1.557	-0.108	-0.025
36.00p	1.32a	1.528	-0.130	-0.029
38.00p	1.51a	1.496	-0.154	-0.034
40.00p	1.69a	1.464	-0.178	-0.040

**Note:**  
Residual Righting Arms shown above are in excess of the turn heeling arms for a 4.5 knot turn with a radius of -8.0 m turning to the left.

**Figure 130: Righting lever as a function of heeling angle**



**Figure 131: Righting lever arm curve calculated for the FV CONDOR on the day of the accident**

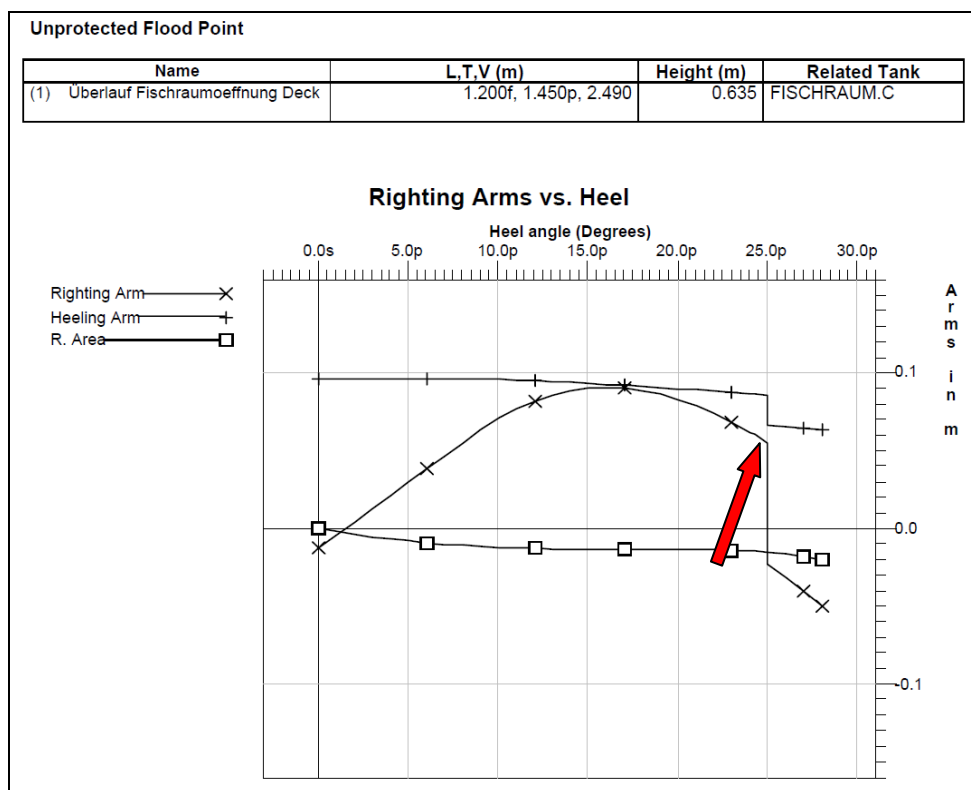
**Conclusion:**

In this load condition and weighing a total of 59.37 t, the FV CONDOR has an initial list of 1.45° to port at the time of the accident. The value of the initial stability GZ is 0.485 m and the range of stability has an angle of 31° to port and 33° to starboard.

A turning circle to the starboard side produces a heeling arm **to the** port side from the centrifugal force. The heeling arms calculated here from this centrifugal force are greater than the fishing vessel's righting levers in the entire angular range to the port side. This means that the fishing vessel capsizes in the turning circle toward the port side.

**B.1.1 Impact of the fish hold flooding due to open bolting on deck**

The following calculation aims to evaluate the possible impact of the fish hold flooding because the facts available leave open the possibility that the round fish hold bolting (Ø 350 mm) was either missing or torn off by the fish chute when the vessel capsized.



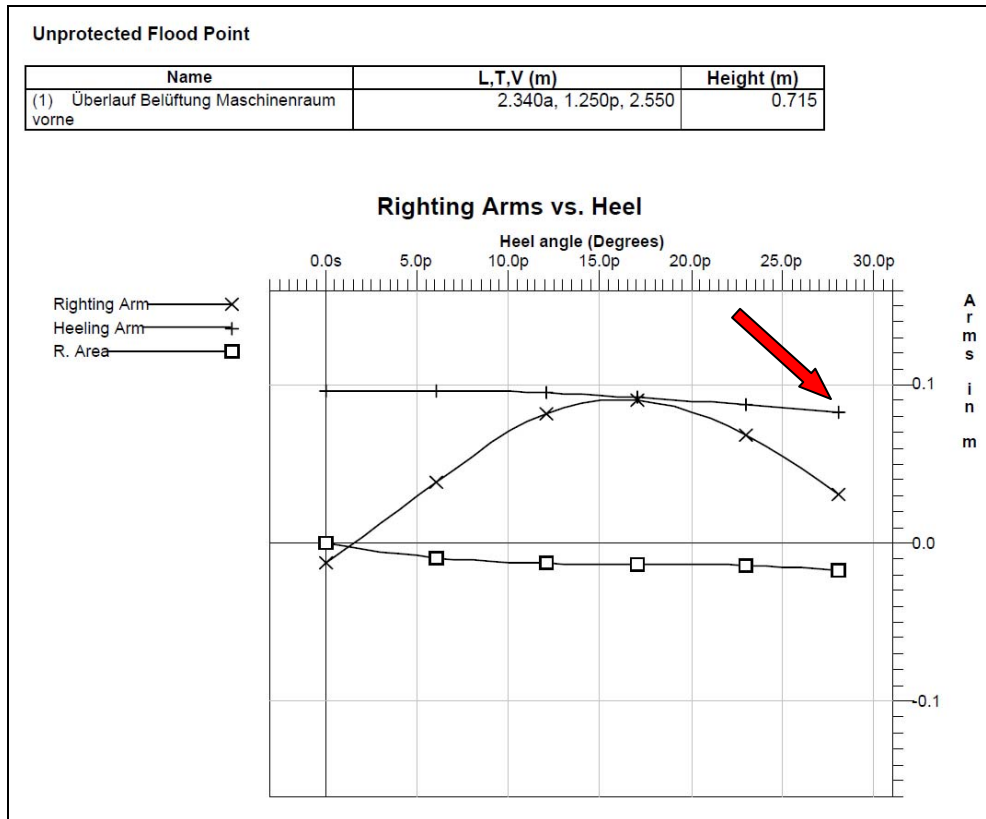
**Figure 132: Impact on the righting lever arm curve of water ingress in the fish hold**

**Conclusion:**

At a heeling angle to the port side of 25°, water runs through the open fish hold bolting into the fish hold and accelerates the capsize to the port side because the righting lever reduces considerably faster than the heeling arm when water flows in.

**B.1.2 Flooding of the engine room through the open inlet air flap**

A below calculation aims to determine the angle from which the engine room starts to flood over the port side.



**Figure 133: Impact on the righting lever arm curve of water ingress in the engine room**

**Conclusion:**

At a heeling angle of about 28° to the port side, water flows into the engine room through the open inlet air flap. This means that the fish hold is flooded first and shortly afterwards the engine room.

**C. Precise de facto course of the accident**

There are no witness statements on the course of the accident. The precise de facto course of the accident involving the foundering of the FV CONDOR was determined on the basis of the analysis of the facts used in this investigation and the corresponding calculations.

The fishing vessel sails out of the port of Burgstaaken at about 0647 on 6 February 2016 for a one-day fishing voyage. She is manned by two people: the skipper (S) and a crew member (C).

Three hauls are completed in the morning. The productive catch of about 1.0 t of cod per haul is stowed on deck in hurdles. The fish hold is not used for storing the catch. As usual, the fish already taken on board are sorted, slaughtered and stowed in crates on deck parallel to the fishing activities. About 3,000 kg of fish and the fish crates are on deck with a centre of mass on the port side.

*The fourth catch is hauled in at about 1120. The fishing vessel is situated in southerly wind of force 5 Bft with her starboard side windward so as to hoist the net on the winch. Her course is roughly 30-90°.*

*In this situation, S will most likely also operate the outside net-winding winch using the control unit near the starboard wheelhouse door. C operates the trawl winch to catch the trawl boards. S goes into the wheelhouse from time to time to correct the course by steering or operating the engine so that the winch reels in the net properly. At the end of this process, C has used the bobby winch to haul in the net's codend so that it is retracted above the bulwark. The codend is hanging on the bobby runner; this is guided through the bobby block, which is hanging high up.*

*In the meantime, S has hauled in the net so far that it is hanging tightly on the side of the shell plating very well filled. Most of the load from this section of the net is also directed above via the bobby block. At this point, the fishing vessel has a slight list of 1.45° to the port side.*

*Given the excellent catch, which is still in the net, S returns to the wheelhouse and uses his phone at 1129 and 1132 to call, inter alia, the fishermen's cooperative to report his catch and request additional people for the slaughtering work. The two phone calls do not give any reason to believe there were uncertainties, a technical malfunction or other irregularities on board. The statements of S are said to have been objective and calm.*

*During the second call, the fishing vessel's course altered toward the south. The fishing vessel then picks up speed and turns to starboard. The speed increases to 4.5 kts in the following two minutes. During the call or immediately afterwards, S has apparently put the rudder to hard to starboard and set the engine to ahead. It is reasonable to assume that S intended this manoeuvre to bring the fishing vessel back into a position in which the net is windward, so as to empty the catch from the sections of the net on board and stow it accordingly.*

*At about 1135, the speed suddenly decreases during the starboard turning circle. At this point, the fishing vessel apparently heels heavily to port as a result of the turning circle moment from the centrifugal force and capsizes.*

*The deck area is flooded through the open freeing ports in the bulwark. At this point, the fishing vessel loses her fish chute, which is stowed near the port side railing above the round deck opening on the port side. It is not possible to clarify whether the deck opening was open or also tore off with the fish chute.*

*The fish hold quickly fills with water through the open deck cover on the port side at a heel angle of 25° and above. This water ingress once more reduces the fishing vessel's righting lever sharply. At a heeling angle of 28°, the engine room starts to flood via an inlet air opening on the deckhouse. The buoyancy of the wheelhouse initially prevents the fishing vessel from rolling over but this also floods quickly and she capsizes further.*

*At 113605, the INMARSAT C antenna mounted on the port side submerges. There is no time for S to send a distress call or fire distress signals. He leaves the wheelhouse via the starboard side and finds himself floating in the water, just like C. The wheelhouse door slammed shut again while crawling out of the fishing vessel, which is on his port side.*

The engine room and forward cabin are flooded with water via the fish hold and the open doors. The fishing vessel capsizes further. She then drifts in a northerly direction due to current and wind, until foundering completely at about 1142. The wreck of the fishing vessel rotates while foundering and she finally lies with her starboard side on the seabed. As she is foundering, the hydrostatic release unit causes the liferaft's mount to open. The liferaft floats toward the surface until its painter/release cord in the liferaft's container is caught. The liferaft is pulled down with the wreck and cannot inflate.

#### **D. Assessment of the FV CONDOR's stability**

##### **D.1 Guideline for fishing vessels < 24 m in length (according to Article 6(1)(6) of the Ship Safety Ordinance)**

The assessment is made based on the stability criteria and certain load cases under the Guideline for fishing vessels < 24 m in length of 1 January 2009.

Section 6.4 of the Guideline states that the following provisions must be observed with regard to the range of stability and manner in which it is determined:

"By way of derogation from Section III, Regulation 2, in conjunction with Regulations 1 and 7 of the Torremolinos Protocol, the following stability criteria may be applied to covered fishing vessels:

righting lever (m) at

30° inclination  $\geq 0.20$  m;

initial stability, corrected for free surfaces (GM)  $\geq 0.35$  m;

surface beneath the righting lever arm curve up to 30° inclination  $\geq 0.055$  m x radian;

surface beneath the righting lever arm curve up to 40° inclination  $\geq 0.090$  m x radian;

surface beneath the righting lever arm curve 30-40° inclination  $\geq 0.030$  m x radian;

range of stability  $\geq 60^\circ$ .

The righting lever arm curves must be calculated and displayed with the weight centre of gravity above the keel (KG) increased by the influence of free surfaces. For vessels with a complete superstructure, the initial stability GM may be less than 0.35 m but must not be less than 0.15 m.

Important operating states are:

- sailing for the fishing grounds fully equipped with fuel, supplies, ice, fishing gear, etc.;
- leaving the fishing grounds with a full catch and 50% of supplies, fuel, etc.;
- arriving at the port of destination with a full catch and 10% of supplies, fuel, etc.;
- arriving at the port of destination with 20% of the full catch and 10% of supplies, fuel, etc. (unsuccessful voyage), and
- unfavourable operating states (if they occur). [...]"

Section 6.5 of the Guideline lays down the following with regard to the procedure for proving stability:

"A simplified proof of stability is sufficient for covered fishing vessels < 18 m in length with a conventional German hull shape. This requires a combined inclining and roll period test in the presence of an inspector from the Administration or a recognised organisation. If the analysis of the combined test produces insufficient or only limited stability values, then the Administration may require a complete proof of stability with righting lever arm curves."

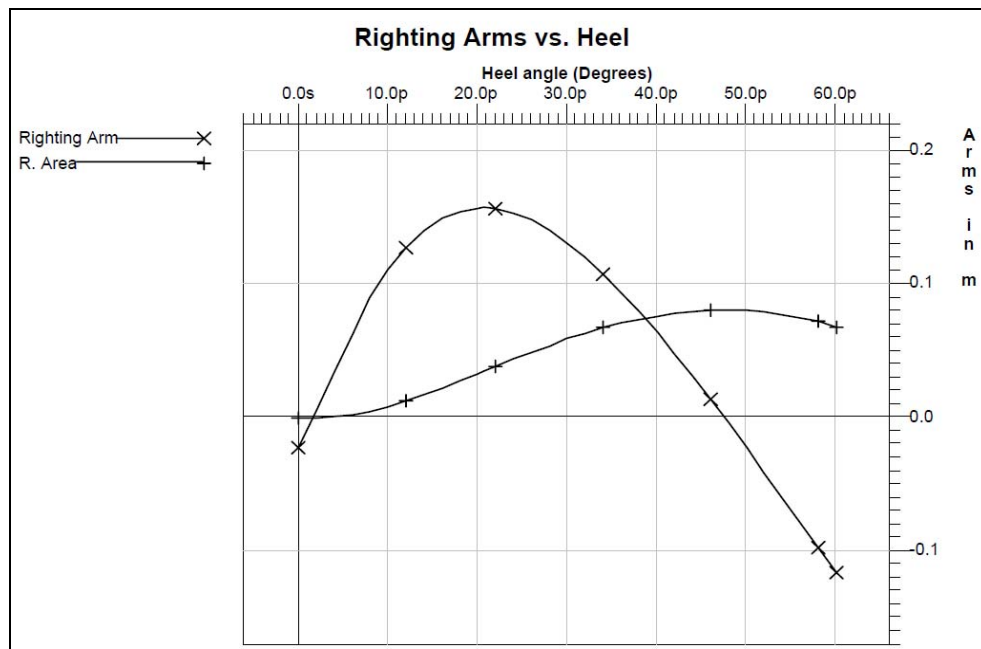
**D.1.1 Assessment of the FV CONDOR's stability – load case 1**

Fishing vessel with mass 'EMPTY SHIP', as determined in this investigation, 120 empty fish crates, crew, full supplies, 5 t of ice in the fish hold in the centre of gravity of water (without free surfaces).

Nr.	Bezeichnung	Masse (kg)	LCG (m)	VCG (m)	TCG (m)
1	Masse LEERES SCHIFF FK "CONDOR" ohne Tankfüllung	53300	0,674	2,009	0,000
2	Crew	200	-0,300	4,000	-0,500
3	Diesel Tank, B.B.-Seite	1920	4,214	1,649	1,170
4	Diesel Tank, S.B.-Seite	1370	3,631	1,639	-1,273
5	Frishwasser Tank, vorne	100	-6,714	2,5	0,000
6	Lose Fischkisten, 60 Stk.	504	3,250	3,250	2,000
7	Eis im Fischraum	5000	-0,518	0,870	0,000
<b>Masse FK im Lastfall 1</b>		<b>62394</b>	<b>0,758</b>	<b>1,916</b>	<b>0,023</b>

Floating Status					
Draft FP	1.814 m	Heel	port 1.58 deg.	GM(Solid)	0.820 m
Draft MS	1.893 m	Equil	Yes	F/S Corr.	0.000 m
Draft AP	1.971 m	Wind	Off	GM(Fluid)	0.820 m
Trim	aft 0.56 deg.	Wave	No	KMt	2.735 m
LCG	0.758a m	VCG	1.916 m	TPcm	0.59
Displacement	62.40 MT	WaterSpgr	1.013		

**Figure 134: FV CONDOR stability calculation – load case 1**



**Figure 135: Righting lever arm curve of the FV CONDOR – load case 1**

Limit	Min/Max	Actual	Margin	Pass
(1) Area from 0.00 deg to 30.00	>0.0550 m-R	0.059	0.004	Yes
(2) Area from 0.00 deg to 40.00	>0.0900 m-R	0.076	0.014	No
(3) Area from 30.00 deg to 40.00	>0.0300 m-R	0.017	0.013	No
(4) Righting Arm at 30.00 deg or MaxRA	>0.200 m	0.131	0.069	No
(5) Angle from 0.00 deg to RAzero	>60.00 deg	48.00	12.00	No
(6) GM Upright	>0.350 m	0.819	0.469	Yes

**Figure 136: Comparison between the Guideline's stability requirements and values of the FV CONDOR – load case 1**

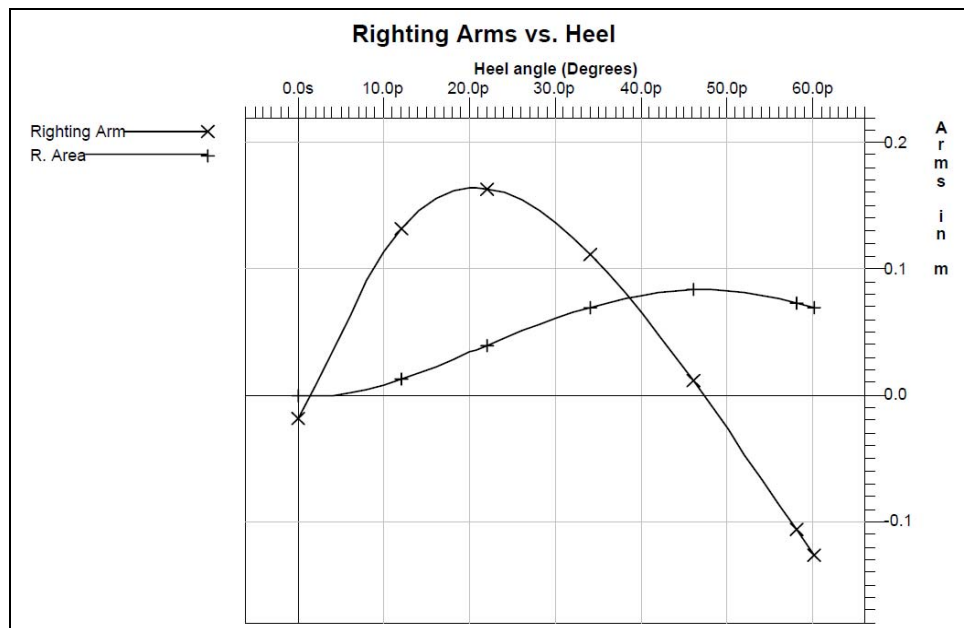
**D.1.2 Assessment of the FV CONDOR's stability – load case 2**

Fishing vessel with mass 'EMPTY SHIP', as determined in this investigation, 2 t of fish on deck and 5 t of fish in the hold, crew, half supplies. For the distribution of mass and the centre of gravity of the fish on deck, uniform distribution is assumed, as adopted in this investigation. The centre of gravity of the mass fish in the fish hold is assumed to be 5 t water in the centroid of the volume (without consideration of free surfaces).

Nr.	Bezeichnung	Masse (kg)	LCG (m)	VCG (m)	TCG (m)
1	Masse LEERES SCHIFF FK "CONDOR" ohne Tankfüllung	53300	0,674	2,009	0,000
2	Crew	200	-0,300	4,000	-0,500
3	Diesel Tank, B.B.-Seite	960	4,079	1,450	1,095
4	Diesel Tank, S.B.-Seite	690	3,543	1,435	-1,192
5	Frischwasser Tank, vorne	50	-6,714	2,300	0,003
6	Fisch an Deck	2000	-0,803	2,999	0,509
7	Fisch im Fischraum	5000	-0,518	0,870	0,000
<b>Masse FK im Lastfall 2</b>		<b>62200</b>	<b>0,606</b>	<b>1,941</b>	<b>0,018</b>

Floating Status					
Draft FP	1.918 m	Heel	port 1.34 deg.	GM(Solid)	0.792 m
Draft MS	1.896 m	Equil	Yes	F/S Corr.	0.005 m
Draft AP	1.873 m	Wind	Off	GM(Fluid)	0.787 m
Trim	fwd 0.16 deg.	Wave	No	KMt	2.732 m
LCG	0.606a m	VCG	1.941 m	TPcm	0.59
Displacement	62.20 MT	WaterSpgr	1.013		

**Figure 137: FV CONDOR stability calculation – load case 2**



**Figure 138: Righting lever arm curve of the FV CONDOR – load case 2**

Limit	Min/Max	Actual	Margin	Pass
(1) Area from 0.00 deg to 30.00	>0.0550 m-R	0.062	0.007	Yes
(2) Area from 0.00 deg to 40.00	>0.0900 m-R	0.080	0.010	No
(3) Area from 30.00 deg to 40.00	>0.0300 m-R	0.018	0.012	No
(4) Righting Arm at 30.00 deg or MaxRA	>0.200 m	0.137	0.063	No
(5) Angle from 0.00 deg to RAzero	>60.00 deg	46.00	14.00	No
(6) GM Upright	>0.350 m	0.786	0.436	Yes

**Figure 139: Comparison between the Guideline's stability requirements and values of the FV CONDOR – load case 2**

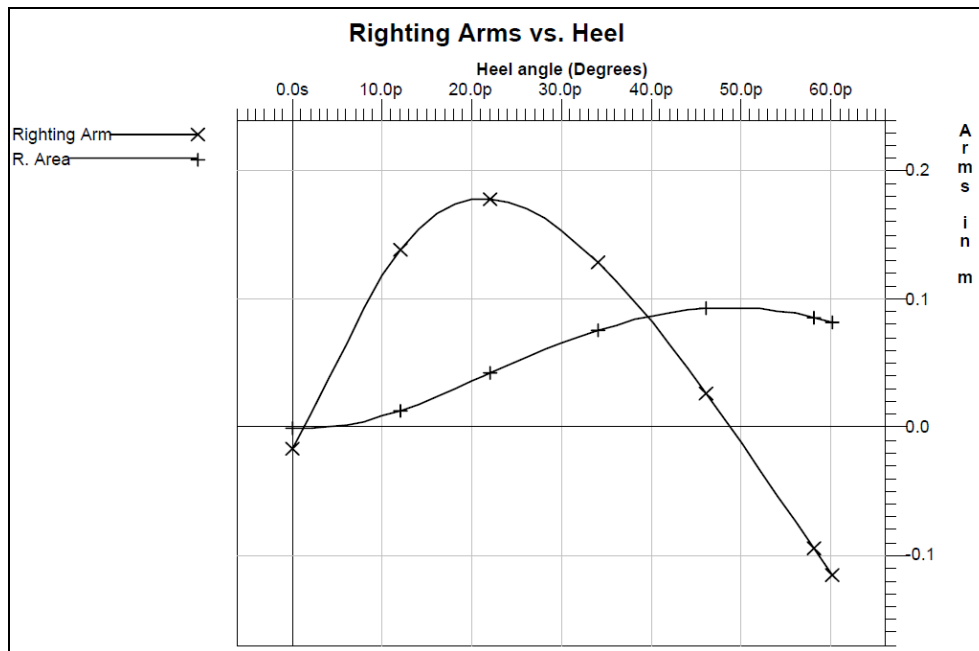
**D.1.2 Assessment of the FV CONDOR's stability – load case 3**

Fishing vessel with mass 'EMPTY SHIP', as determined in this investigation, 2 t of fish on deck and 5 t of fish in the hold (each in crates), crew, 10% supplies. Distribution of mass and centre of gravity fish on deck and in hold as in D.1.2.

Nr.	Bezeichnung	Masse (kg)	LCG (m)	VCG (m)	TCG (m)
1	Masse LEERES SCHIFF FK "CONDOR" ohne Tankfüllung	53300	0,674	2,009	0,000
2	Crew	200	-0,300	4,000	-0,500
3	Diesel Tank, B.B.-Seite	190	3,665	1,202	1,045
4	Diesel Tank, S.B.-Seite	140	3,305	1,189	-1,116
5	Frischwasser Tank, vorne	10	-6,714	2,140	0,013
6	Fisch an Deck	2000	-0,803	2,999	0,509
7	Fisch im Fischraum	5000	-0,518	0,870	0,000
<b>Masse FK im Lastfall 3</b>		<b>60840</b>	<b>0,538</b>	<b>1,950</b>	<b>0,016</b>

Floating Status					
Draft FP	1.944 m	Heel	port 1.15 deg.	GM(Solid)	0.785 m
Draft MS	1.875 m	Equil	Yes	F/S Corr.	0.002 m
Draft AP	1.806 m	Wind	Off	GM(Fluid)	0.783 m
Trim	fwd 0.49 deg.	Wave	No	KMt	2.735 m
LCG	0.538a m	VCG	1.950 m	TPcm	0.58
Displacement	60.84 MT	WaterSpgr	1.013		

**Figure 140: FV CONDOR stability calculation – load case 3**



**Figure 141: Righting lever arm curve of the FV CONDOR – load case 3**

Limit	Min/Max	Actual	Margin	Pass
(1) Area from 0.00 deg to 30.00	>0.0550 m-R	0.066	0.011	Yes
(2) Area from 0.00 deg to 40.00	>0.0900 m-R	0.087	0.003	No
(3) Area from 30.00 deg to 40.00	>0.0300 m-R	0.021	0.009	No
(4) Righting Arm at 30.00 deg or MaxRA	>0.200 m	0.153	0.047	No
(5) Angle from 0.00 deg to RAzero	>60.00 deg	48.00	12.00	No
(6) GM Upright	>0.350 m	0.782	0.432	Yes

**Figure 142: Comparison between the Guideline's stability requirements and values of the FV CONDOR – load case 3**



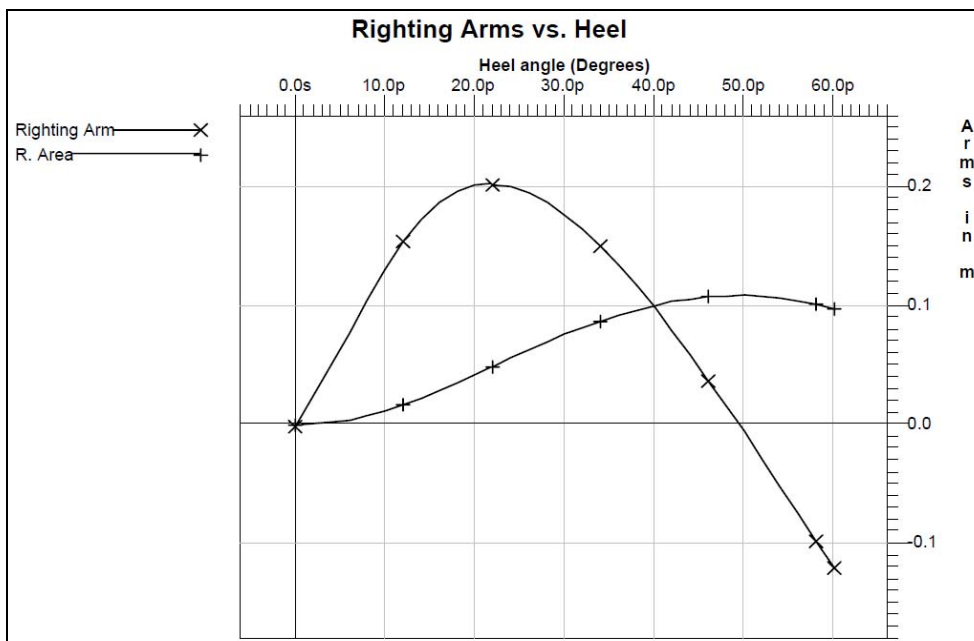
**D.1.4 Assessment of the FV CONDOR's stability – load case 4**

Fishing vessel with mass 'EMPTY SHIP', as determined in this investigation, 0.4 t of fish on deck and 1 t of fish in the hold (each in crates), crew, 10% supplies. For the distribution of mass and the centre of gravity on deck, uniform distribution is assumed, as adopted in this investigation. The centre of gravity of the mass fish in the fish hold is assumed to be 1 t water in the centroid of the volume (without consideration of free surfaces).

Nr.	Bezeichnung	Masse (kg)	LCG (m)	VCG (m)	TCG (m)
1	Masse LEERES SCHIFF FK "CONDOR" ohne Tankfüllung	53300	0,674	2,009	0,000
2	Crew	200	-0,300	4,000	-0,500
3	Diesel Tank, B.B.-Seite	190	3,665	1,202	1,045
4	Diesel Tank, S.B.-Seite	140	3,305	1,189	-1,116
5	Frischwasser Tank, vorne	10	-6,714	2,140	0,013
6	Fisch an Deck	400	-1,810	2,880	0,350
7	Fisch im Fischraum	1000	-0,284	0,573	0,000
<b>Masse FK im Lastfall 4</b>		<b>55240</b>	<b>0,651</b>	<b>1,992</b>	<b>0,002</b>

Floating Status					
Draft FP	1.780 m	Heel	port 0.11 deg.	GM(Solid)	0.766 m
Draft MS	1.775 m	Equil	Yes	F/S Corr.	0.002 m
Draft AP	1.769 m	Wind	Off	GM(Fluid)	0.764 m
Trim	0.04 deg.	Wave	No	KMt	2.757 m
LCG	0.651a m	VCG	1.992 m	TPcm	0.57
Displacement	55.24 MT	WaterSpgr	1.013		

**Figure 143: FV CONDOR stability calculation – load case 4**



**Figure 144: Righting lever arm curve of the FV CONDOR – load case 4**

Limit	Min/Max	Actual	Margin	Pass
(1) Area from 0.00 deg to 30.00	>0.0550 m-R	0.076	0.021	Yes
(2) Area from 0.00 deg to 40.00	>0.0900 m-R	0.101	0.011	Yes
(3) Area from 30.00 deg to 40.00	>0.0300 m-R	0.025	0.005	No
(4) Righting Arm at 30.00 deg or MaxRA	>0.200 m	0.177	0.023	No
(5) Angle from 0.00 deg to RAzero	>60.00 deg	48.00	12.00	No
(6) GM Upright	>0.350 m	0.764	0.414	Yes

**Figure 145: Comparison between the Guideline's stability requirements and values of the FV CONDOR – load case 4**

**D.1.5 Conclusion:**

The following criteria are **not** satisfied in any of the four load cases:

- righting lever arm at 30° inclination ≥ 0.20 m;
- surface beneath the righting lever arm curve between 30° and 40° ≥ 0.030 m x radian;
- range of stability ≥ 60°

At 46-48°, the range of stability is extremely low in all load cases and far less than the required 60°. The apex of the righting lever curve is 20-22° in all cases and then drops quite sharply again. The early apex with the righting lever at a relatively small value of 0.16-0.20 m still produces quite high initial stability GM of 0.76-0.82 m.

In combination with the high centre of mass, this type of ship is an example of the fact that high initial stability is not necessarily meaningful for the stability behaviour of a ship. Quite the opposite, it can be surmised that external moments cause stronger movements because of the high initial stability.

This dynamic behaviour was not investigated further here. Given this configuration, it is reasonable to expect that greater heeling angles will develop for which – in conjunction with her high centre of mass – this type of ship will cease to have a righting lever.

**D.2 Assessment of the See-BG's proof of stability of 2005/2006**

The approved proof of stability of See-BG for the FV CONDOR of 1 August 2006 assumes a maximum load of 7 t, where 5 t is in the hold and 2 t is on deck. This proof of stability underlies the fishing vessel safety certificate, which is valid until 18 August 2018.

It is based on the findings of the combined roll period and inclining test of 5 October 2005. GL<sup>37</sup> carried out the analysis of this test.

**Comparison of the findings of the expert's opinion under D.1.3 with those of the combined roll period and inclining test of 5 October 2005:**

	<b>Findings from D.1.3</b>	<b>GL report of 2006</b>	<b>Difference to the GL report</b>	<b>%</b>
<b>Displacement (t)</b>	60.84	65.34	<b>-4.5 t</b>	<b>-6.9</b>
<b>Draught (base in m)</b>	1.87	1.86	<b>+0.01</b>	<b>+0.5</b>
<b>Freeboard at ½ Lpp (m)</b>	0.46	0.50	<b>-0.04</b>	<b>-8.0</b>
<b>KG (m)</b>	1.99	1.82	<b>+0.17</b>	<b>+9.3</b>
<b>GM (m)</b>	0.78	0.61	<b>+0.17</b>	<b>+27.9</b>
<b>Righting lever at 30°</b>	0.15	0.22	<b>-0.07</b>	<b>-31.8</b>

Note:

- Load case 3 largely corresponds to the recorded conditions of the roll period and inclining test.
- The **minimum freeboard** in load case 3 on Frame +3.902 is **0.32 m**.

<sup>37</sup> Note by the BSU: GL and the Norwegian classification society Det Norske Veritas (DNV) merged in the autumn of 2013 to form DNV GL.

### **D.2.1 Conclusion:**

*Both calculations are based on almost the same draughts. The difference here is only about 0.5%. This means that the sinkage between 2005 and 2016 was only insignificant. A large increase in mass due to additional fixtures has thus not taken place.*

*The displacement in the GL report is 4.5 t higher than the current displacement, which was determined very precisely. Some of the other values of relevance to stability also differ widely from one another. This implies that the analysis made in 2005 was not carried out using the exact shape of the FV CONDOR but with a scaled comparison vessel.*

*As a result of this investigation, it can be stated that the combined roll period and inclining test of 5 October 2005 and its analysis selected in this context **failed to** yield accurate results as regards the values of relevance to the FV CONDOR's stability.*

## **E. Deficits and possible sources of error in the expert opinions**

### **E.1 Determination of mass and centres of gravity 'EMPTY SHIP'**

*The original intention was to carry out the assessment of the mass 'EMPTY SHIP' with the aid of an inclining test on the raised fishing vessel. This was not possible immediately after the salvage operation because the insulation was full of water.*

*Safety concerns of the WSA meant that a test planned for early summer could not be carried out at the intended location. The method of determining the mass and centre of gravity 'EMPTY SHIP' chosen in this investigation is sound and underpinned by an error analysis.*

### **E.2 Mass 'Fish on deck' at the time of the accident**

*The mass 'Fish on deck' after the first three hauls is assumed for this calculation based on the skipper's phone calls. There is a certain amount of uncertainty and margin here. The positions of the fish masses on deck are based on the potential stowage positions.*

*Undisputed is the fact that the fish hold was empty (contrary to the requirements of the 2005 proof of stability). With the assumed and calculated scenario, the fishing vessel had to capsize in the turning circle.*

*According to the results of the calculations, she would also have capsized if the load on deck was even greater.*

### **E.3 Turning circle**

*The assessment of the turning circle was made using the AUTOHYDRO software tool for turning circle-induced heeling moments. This approach is conclusive and traceable.*

*However, since the consideration of the turning circle concerns a dynamic process, the approach applied here can only represent a simplified method. A detailed numerical calculation of this complex issue would increase the accuracy of the assessment."*

## 4 Analysis

### 4.1 Reconstruction of the courses of the voyage and accident

The FV CONDOR's AIS transmitter had not been switched on during the day of the accident for reasons that could no longer be explained. As a small fishing vessel, she was not required to carry a VDR. The BSU's attempts to extract track data from the navigation equipment installed on the bridge of the fishing vessel also failed. Since there were no eyewitnesses who could provide information on the course of the fishing vessel's voyage on the day of the accident, either, the radar recording of VTS Travemünde was the only source available for reconstructing the track of the vessel. According to the BSU's findings, the relevant radar station is equipped with modern high-resolution technology. Nevertheless, the system-related weaknesses of the radar technology limited the options for analysing the radar images. It should also be noted here that the FV CONDOR was a relatively small vessel, which evidently made a radical course alteration immediately before the accident.

The analysis of the BLE's GPS-based recordings and reading out the antenna installed on board the fishing vessel failed to make a decisive contribution to obtaining a picture of the course of the voyage that was completely reliable due to the sparseness of the data available in each case. The BLE's data did make an important contribution to the investigation of the course of the FV CONDOR's voyage, however. The information stored in the BLE antenna shows that the fishing vessel almost certainly capsized at 1136. Furthermore, the data also show indirectly that there were no unusual incidents on board on the day of the accident, as information on such incidents (e.g. power outages) would have been stored in the BLE antenna's memory via the log function.

Subject to inaccuracies inherent to the system in combination with the position of the rudder during the salvage operation, the findings gained from the BLE's data and the fact that the fishing vessel's skipper informed the fishermen's cooperative by phone at 1130 about a productive catch, VTS Travemünde's radar recordings permit the following conclusions:

- (1) the FV CONDOR left the port of Burgstaaken at about 0647 on 6 February 2016 for a one-day fishing voyage northeast of Fehmarn/Staberhuk. In the morning, three hauls of fish were transferred to the deck with the net. They were stored and partially processed only on the main deck;
- (2) at about 1120, they started to bring the fourth haul out of the water. However, for reasons that could no longer be explained but presumably due to a lack of space on the main deck, the crew decided not to empty the net completely. Instead, the two crew members merely used the bobby winch to hoist the net's completely filled codend high enough to allow it to be swung above the bulwark.

- The codend's load acted on the bobby runner, which in turn was guided through the bobby block hanging high up in the mast. The reconstruction of the net and line arrangement also revealed that the net had been hoisted with the net-winding winch to such an extent that it – again extremely well filled – hung laterally on the shell plating on the starboard side. Most of the load from this section of the net also acted on the bobby block, i.e. several metres above the main deck;
- (3) it was not possible to clarify whether the skipper intended to return to his port of registry with the 'tied-in' net or whether he wanted to take it back on board at a later point in time during the return voyage;
  - (4) however, it is certain that the fishing vessel picked up speed after the activities discussed above and started to turn onto a course for the home port with the rudder position on hard to starboard. The radar data also show that the CONDOR increased her speed to about 4.5 kts. At about 1135, the speed suddenly decreased during the turning circle. At this point, the fishing vessel must have heeled heavily to port as a result of the turning circle moment from the centrifugal force and capsized, as the righting forces were apparently lower than the heeling moment to port;
  - (5) the deck area was flooded due to the open freeing ports in the bulwark. At this point, the fishing vessel lost her fish chute, which was mounted on the port side. The fish hold quickly filled with water through the open deck cover on the port side at a heel angle of 25° and above. This dramatically reduced the fishing vessel's righting lever further. At a heeling angle of 28°, the engine room started to flood via an inlet air opening on the deckhouse;
  - (6) there was no time left for the crew to make a distress call, fire distress signals or put on a lifejacket. Both men fell into the cold Baltic Sea, and
  - (7) at about 1142, the fishing vessel foundered completely.

#### **4.2 Failure of the liferaft**

The examination of the liferaft, which was last serviced in December 2015 by an authorised service station of the manufacturer in Denmark, in the presence of representatives of the manufacturer led to the unequivocal conclusion that the special sachet containing the painter/release cord, which was not stowed in accordance with the manufacturer's specifications and clear service instructions when the service was carried out, was the reason why the cord in question was unable to glide out of the liferaft's container.

The cord caught due to the incorrect stowage of the sachet inside the container and trapped it to the wreck of the fishing vessel as she foundered.

Given that the results of the forensic examination showed that the two crew members had not been seriously injured when the fishing vessel capsized but that drowning was the sole cause of death, there is much to suggest that they would have survived the marine casualty if instead of the container with the liferaft being dragged down by the fishing vessel, the liferaft had been able to inflate on the surface as intended.

### 4.3 Failure of the EPIRB

The capsizing of the fishing vessel went completely unnoticed for several hours because the crew had no time left to transmit a distress call and there were no eyewitnesses to the accident. Inquiries of the BSU with MRCC Bremen revealed that at no time was a signal from the fishing vessel's EPIRB received there.

The EPIRB was found floating on the surface of the water at the scene of the accident during the salvage operation. This fact permits the conclusion that the EPIRB only floated up to the surface during the salvage activities. Since the hydrostatic release unit could not be located, it was not possible to determine with absolute certainty whether the EPIRB's 'delayed' buoyancy was due to a technical failure of the hydrostatic release unit.

The ship's files of the FV CONDOR available at the Ship Safety Division (BG Verkehr) show that the EPIRB and the hydrostatic release unit were last officially inspected and approved in October 2015. It is very unlikely that the hydrostatic release unit or the EPIRB's mount failed when the fishing vessel foundered and then started to work a month later. Instead, the overall circumstances suggest that the EPIRB released from its mount properly when the fishing vessel foundered but was then prevented from floating to the surface by one of the fishing vessel's components.

It was not possible to clarify what the obstacle might have been. However, it is clear that the EPIRB's mount was installed properly on the deckhouse of the fishing vessel in accordance with the manufacturer's recommendations. When selecting the mounting position, it had to be taken into account that on one hand it should be possible for the EPIRB to float to the surface as freely as possible in the event of the vessel foundering, but on the other hand, it must also be possible for the crew to reach the EPIRB on board without major difficulties and to release it from the mount manually, so as to quickly take it off the ship if the need arises to abandon the vessel in the liferaft, for example.

The manufacturer's inspection of the EPIRB also revealed that its internal battery was discharged but that otherwise it was fully functional. This suggests that the EPIRB began to transmit properly after contact with the water. However, it was naturally impossible for the transmitted signal to propagate sufficiently under water.

In the course of the investigation, the BSU asked the DGzRS how long it would have taken rescue services to arrive at the scene of the accident if the FV CONDOR's EPIRB had transmitted distress signals from the surface of the water.

The DGzRS is one of the most up-to-date search and rescue organisations in the world and responsible for search and rescue in German coastal waters, in particular. The below information was sent to the BSU.

Depending on the satellite constellation and other special circumstances, the distress signal of an activated EPIRB is received at MRCC BREMEN, which is manned around the clock by experienced navigators and radio operators, within a period of 15-30 minutes. MRCC Bremen has a dual role. On the one hand, it is the operations control centre for its 60 search and rescue units. On the other hand, it is the national co-ordinating body for all maritime search and rescue operations within the German parts of the North Sea and Baltic Sea, for which the DGzRS is responsible.

After the EPIRB signal had been received, the 9.5/10.1 m search and rescue cruiser EMIL ZIMMERMANN stationed in Puttgarden on the island of Fehmarn and/or the 27.5 m search and rescue cruiser BREMEN stationed in Großenbrode (south of the island of Fehmarn) would have been deployed. Taking into account the distances of some 7 nm or 12 nm to be covered up to the scene of the accident and possible brief lead times before the start of the mission, it is reasonable to assume that the search and rescue units would have arrived at the scene of the accident no later than about one hour after the EPIRB activated.

At the same time as activating the rescue units, MRCC Bremen would have transmitted a mayday relay via the associated coastal SAR radio station Bremen Rescue Radio on the designated frequencies to call on vessels near the scene of the accident to assist the distressed vessel. Since there is regular shipping traffic in the vicinity of the scene of the accident, it is not unlikely that a mayday relay would have resulted in the arrival of assistance at the scene of the accident well under one hour after activation of the EPIRB.

Contrary to the widespread belief that a person can only survive in cold water for a very short period of time, studies have shown that the survival rate of healthy, normally dressed people in water with a temperature of 5°C for about an hour is 50 per cent.<sup>38</sup> The water temperature at the scene and on the day of the accident was about 3-4°C. Consequently, it may well have been possible to rescue the two fishermen if the EPIRB had set in motion the rescue sequence immediately after the fishing vessel capsized.

#### **4.4 Identification of the primary cause of the accident**

Neither during the dives on the wreck nor during the inspection of the raised fishing vessel were there indications of contact with an external obstacle, fire or an explosion as the primary cause of the accident.

---

<sup>38</sup> Source: 'Essentials of Sea Survival' – Frank Golden, Michael Tipton; Human Kinetics, Champaign, IL, United States; 2002; p. 139.

Accordingly, the fishing vessel could only have capsized due to stability problems. The assumption that technical problems with the engine, rudder or winch equipment could have been one of the causes of the accident was not confirmed.

#### **4.4.1 Engine, rudder and winches**

The extensive inspection of the engine, steering gear and winches by the expert acting on behalf of the BSU did not deliver any evidence of mechanical, electrical or hydraulic problems on board the fishing vessel on the day of the accident. The maintenance status of the fishing vessel's technical equipment was good and it was most probably fully functional at the time of the accident.

#### **4.4.2 Stability of the fishing vessel**

##### **4.4.2.1 Assessment of the fishing vessel's stability at the time of the accident**

The assessment of the FV CONDOR's hydrostatic properties by the expert acting on behalf of the BSU was made on the basis of a precise, laser-based survey of the fishing vessel and careful determination of the individual masses of the relevant components of the vessel. The expert used a recognised special computer program that is proven in the industry for his subsequent calculations. With that in mind, there is no reason for the BSU to doubt the findings of the expert's stability assessment.

The plausible and conclusive hydrostatic calculations of the expert prove the FV CONDOR would inevitably capsize on the day of the accident under these specific circumstances when she executed the starboard turning circle with a hard-over rudder position.

According to the judgement of the expert, to which the BSU fully subscribes, the factors below caused the accident.

(1) The fishing vessel's high centre of mass due to

- high centre of mass of the vessel ('EMPTY SHIP') without cargo due to her design (or structural modifications made over the decades, e.g. larger winches in comparison to the original design);
- stowage of the fish only on deck and not – as was assumed in the proof of stability of the then See-BG – largely in the lower lying fish hold.<sup>39</sup> (The fish stowed mainly on the port side of the deck also produced a heel to port.);
- hanging load of the codend on the bobby block at a height of 8.90 m over base;

---

<sup>39</sup> Note by the BSU: The stability of the fishing vessel was adequately confirmed in 2006 in a letter to the skipper (owner) by See-BG on the explicit assumption of a load of 7 t (5 t in the hold and 2 t on deck).



- additional load component in this bobby block (which is high above the fishing vessel's base) consisting of the fish in the tight net hanging laterally on the fishing vessel's shell plating in the area of the water line, and
  - fuel tanks only about 18% full, i.e. no significant counterweight in deeper parts of the hull.
- (2) Turning circle to starboard at a speed of about 4.5 kts. This produces a heeling moment from the centrifugal force to the port side. The fishing vessel's earlier heel to the port side facilitates a capsizing in the turning circle.
- (3) Culmination of the fishing vessel's high centre of gravity and unfavourable form parameters. The following hydrostatic parameters are unsatisfactory at the time of the accident:
- behaviour of the righting levers;
  - low maximum righting lever;
  - low range of stability;
  - high initial stability.

The calculations of the expert reveal that the FV CONDOR did not meet the stability requirements defined in the Ship Safety Ordinance (or the stability requirements defined in the ensuing Guideline for fishing vessels < 24 m in length) at the time of the accident.

The following safety criteria were **not** met in any of the four load cases considered by the expert:

- righting lever arm at 30° inclination  $\geq 0.20$  m;
- surface beneath the righting lever arm curve between 30° and 40°  $\geq 0.030$  m x radian;
- range of stability  $\geq 60^\circ$ .

The combined roll period and inclining test carried out on the fishing vessel by See-BG on 5 October 2005 – or rather the method of analysis chosen by GL in this context – produced incorrect results for the values of relevance to the fishing vessel's stability.

With regard to GL's method of analysis, it should be noted in particular that the numerical values determined during the roll period and inclining test carried out in 2005 were evidently transferred to a numerical form model of a scaled comparison fishing vessel used by GL, which did not match the actual shape of the FV CONDOR's underwater hull sufficiently during the subsequent mathematical evaluation. Since there have been no significant structural modifications to the fishing vessel since 2005, this – and possible inaccuracies during the inclining test – is the only plausible explanation for the substantial differences between the stability assessment of GL on the one hand and that of the BSU's expert, on the other.

#### 4.4.2.2 Planned renewal of the proof of stability and the Guideline for fishing vessels

That the planned renewal of the FV CONDOR's proof of stability did not occur before the accident might have been fatal. The ship's files at the Ship Safety Division (BG Verkehr) show that the owner of the fishing vessel was told the following during the routine inspection of the engine on 25 August 2014, inter alia:

*"According to the Guideline for fishing vessels of 2009, proof of stability must be provided every ten years. Therefore, a complete inclining test must be carried out by an authorised engineering firm in the presence of a nautical surveyor from the Ship Safety Division (BG Verkehr) at the latest before the fishing vessel is next put into dry dock in 2016. Notification of the date must be made in good time. The last roll period and inclining test was carried out on 5 October 2005."<sup>40</sup>*

Regardless of the fact that the fishing vessel's proof of stability was not renewed before her accident, the BSU believes that from a legal standpoint it is doubtful whether one could actually be demanded based on current regulations.

It is important to consider that although the Guideline for fishing vessels < 24 m in length – which was published by the Federal Ministry of Transport, Building and Urban Affairs<sup>41</sup> in 2009 on the basis of Article 6(1)(6) of the Ship Safety Ordinance – is designed to put the requirements for ship safety into specific form pursuant to the aforementioned Ordinance within the meaning of Articles 3 and 7 to 9 of the Ship Safety Act, it is merely a list of recommendations on account of the legislative nature the Federal Ministry opted for ('Guideline'), and from a legal standpoint cannot have the same binding effect as would be the case with laws or ordinances enacted on the basis of laws.

In addition, the 'requirement' that proof of stability must be renewed every ten years is not actually contained in the Guideline for fishing vessels, but rather it is provided for by the *Verwaltungsvorschrift der Dienststelle Schiffssicherheit der BG Verkehr zur Umsetzung der Richtlinie nach § 6 Abs. 1 Nr. 6 der Schiffssicherheitsverordnung über Sicherheitsanforderungen an Fischereifahrzeuge mit einer Länge unter 24 m* [administrative regulation of the Ship Safety Division (BG Verkehr) to implement the Guideline for fishing vessels < 24 m in length (according to Article 6(1)(6) of the Ship Safety Ordinance)] of 17 August 2015.

Moreover, with the Guideline for fishing vessels, the specific location of the aforementioned requirement poses a basic legal problem. According to the definition and legal interpretation, administrative regulations are internal instructions, which cannot have a formal effect externally. Rather, they serve – and thus the introductory sentence of the administrative regulation of the Ship Safety Division (BG Verkehr) reads as follows in this specific case – *"to explain and harmonise the Administration's handling of the Guideline for fishing vessels.*

---

<sup>40</sup> Source: Engine report („Bericht Maschine“) of the Ship Safety Division (BG Verkehr) of 25 August 2014.

<sup>41</sup> Note by the BSU: The current name of the ministry is Federal Ministry of Transport and Digital Infrastructure.

*To the extent that the Guideline gives the Administration a margin of manoeuvre (discretion) for its decisions, then this administrative regulation shall be complied with."*

It is self-evident that administrative regulations cannot contain any provisions that in the administration/regulation addressee relationship go beyond what is bindingly regulated in the underlying law and ensuing regulation.

Regardless of the legal problems, it is also important to note that linking a rigid ten-year deadline with the renewal of the proof of stability can also be counterproductive for factual reasons. A primary reason for renewing the proof of stability is when there have been conversions to a vessel that affect stability. Such conversions can have a substantial influence on a vessel's stability characteristics and therefore inevitably require a reassessment of stability, even if such an assessment has been carried out on a rotational basis only a few months earlier.

Finally, the BSU also noted while reviewing the administrative regulation of the Ship Safety Division (BG Verkehr) that information on behaviour in the event of influences detrimental to stability on fishing vessels is annexed to it.

For example, the annex in question contains the following<sup>42</sup>:

*"1. General*

*The most important prerequisite for maintaining satisfactory stability during a voyage is a properly stowed catch that is reliably secured against slipping and weatherproof closure of the hull. Adequate freeboard is also part of seaworthiness.*

*[...]*

*3. Free surfaces and watertight integrity*

*Free surfaces in tanks, bilges or spaces reduce stability. Vessels should therefore be operated with as few tanks with free surfaces as possible. Free surfaces in a fish hold must be avoided by draining in good time.*

*Even a small amount of water ingress in a space reaching from side to side can lead to a considerable degradation of initial stability (down to negative values) due to the effect of the free surface, possibly causing the vessel to start listing randomly to port or starboard. The change of such an equilibrium position toward the other side, e.g. due to swell, is then especially hazardous because of the excess water. In the worst case, a ship can capsize even with low water ingress due to the loss of stability.*

*Preventing water from entering the ship is therefore extremely important. All openings, such as hatches, windows, doors, ventilators, air ducts, etc., must be closed and made weatherproof in good time using their intended closing devices. When working on outboard fittings it must be ensured that water cannot enter.*

*[...]*

---

<sup>42</sup> Administrative regulation of the Ship Safety Division (BG Verkehr) to implement the Guideline for fishing vessels < 24 m in length (according to Article 6(1)(6) of the Ship Safety Ordinance) of 17 August 2015; Annex to No 6.

### **7. Hard-over rudder position**

***A hard-over rudder position at full speed always causes the vessel to heel toward the centrifugal force when she starts to turn. The extent of such heeling can become dangerously high if the vessel's stability values are low and the speed is high. This behaviour of the ship is also evident at lower rudder positions. Ship's commands should urgently seek to improve stability by taking appropriate measures, such as flooding low lying tanks, upon becoming aware of this.***<sup>43</sup>

[...]"

The BSU believes that from a technical point of view the cited information is extremely valuable and had it been observed in full could have made an important contribution to preventing the accident involving the FV CONDOR. It concerns the substantive and, indeed, verbatim reproduction of the *H 1 Richtlinien für das Verhalten bei stabilitätsgefährdenden Einflüssen auf Fischereifahrzeugen* [guidelines for behaviour in the event of influences detrimental to stability on fishing vessels] published by See-BG on 21 September 1989. The purpose of such guidelines was to expand upon and explain the [German] Accident Prevention Regulations for Shipping Enterprises (UVV See). As part of the extensive reform of the UVV See in 2010, a large number of standards from the body of rules in question was repealed with effect from 1 January 2011. This also affected the aforementioned H 1 guidelines successively.

Although this information is now annexed to an internal administrative regulation, its sole purpose can only be to enable the Administration to apply the Guideline for fishing vessels in a uniform manner. In contrast, by its very nature the information on behaviour in the event of influences detrimental to stability on fishing vessels is still directed primarily at the skippers and crews of fishing vessels and must therefore in future be incorporated into binding regulations or recommendations addressed directly to this audience.

## **4.5 Other underlying conditions**

### **4.5.1 Fishing vessel's maintenance status and certificates**

In particular given her advanced age, the FV CONDOR was in good structural condition. The BSU's initial assumption that the GRP coating might have led to damage to the wooden hull that would have caused the accident was not confirmed in the course of the assessment of the vessel. The fishing vessel also met all the formal requirements. She had valid certificates and was properly equipped in all respects, especially with regard to the rescue equipment on board. It was not possible to determine why the required AIS system had not been switched on during the day of the accident.

---

<sup>43</sup> Emphasised by the BSU because of the significance of this information to the actual course of events surrounding the accident.

#### **4.5.2 Qualifications and experience of the crew**

The fishing vessel's skipper was undoubtedly a very experienced fisherman. He took over the CONDOR from her previous owner in 1997. Therefore, it is reasonable to assume that the fishing vessel's skipper was perfectly acquainted with her handling characteristics due to his almost 20 years of working on her.

In the course of acquiring certificates of proficiency, skippers from this professional group also cover the theory of ship stability. However, the curriculum here is not as extensive as would be the case when obtaining certification as an officer in charge of a navigational watch in global merchant shipping or fishing on the high seas, for example.

These differences in curriculum are generally compensated for in favour of skippers working in coastal fishing by the fact that in most cases fishing formed part of their earliest childhood and they grew up with it. Moreover, thanks to working on board their vessels on a daily basis with the most varied of weather conditions and catch sizes, they are also familiar with the handling characteristics and sea-keeping qualities.

Taking into account the above considerations, the BSU finds it impossible to understand why the CONDOR's skipper was apparently unaware of the dangers posed by gradually loading the fishing vessel with a substantial amount of fish on the day of the accident but completely dispensing with the use of the fish hold in the process.

The second crew member of the fishing vessel was also an experienced fisherman. It is no longer possible to clarify whether he had reservations about dispensing with the use of the fish hold.

#### **4.5.3 Fatigue and alcohol**

The two crew members sailed out for the fishing voyage on the morning of the day of the accident. There is no evidence to suggest that fatigue, physical exhaustion or concentration difficulties could have triggered the accident. Moreover, neither fisherman was under the influence of alcohol.

#### **4.5.4 Lifejacket and floatation waistcoat**

Neither crew member of the fishing vessel was wearing a lifejacket or floatation waistcoat while working. As already discussed above, the cause of death was found to be drowning in both cases. The course of the accident was marked by the fact that the rescue sequence was not set in motion until several hours after the fishing vessel capsized due to the failure of the EPIRB and for lack of a distress call. Given the water temperatures in winter, it is safe to assume that in this specific accident scenario the two crew members would have lost their lives (i.e. frozen to death) even if they were wearing lifejackets or floatation waistcoats.

## 5 Conclusions

### 5.1 Primary cause of the accident and consequences

Despite the uncertainties as to the actual course of the accident for lack of technical recordings or eyewitnesses, it is almost certain that the FV CONDOR capsized while making the turning circle because her stability characteristics were problematic and did not comply with the provisions of the Guideline for fishing vessels. This basic risk factor was increased further on the day of the accident by the fact that the fishing vessel's crew dispensed with stowing the catch in the dedicated fish hold below the main deck.

In the opinion of the expert appointed by the BSU, to which the BSU fully subscribes, the proof of stability made in 2005/2006 was evidently based on an erroneous analysis by GL of the parameters determined during the combined roll period and inclining test. In this respect, the exact shape of the FV CONDOR was not taken as a basis, but rather that of a scaled comparison vessel. It is no longer possible to determine whether errors occurred during the determination of the parameters.

Apart from the errors in the content of the proof of stability issued by the then See-BG on 1 August 2006, the BSU considers it highly questionable that it is based on the premise of a payload of 5 t in the hold and 2 t on deck (simultaneously!), without the inclusion of an explicit requirement in this respect. The document referred to merely states that the appended guidelines for behaviour in the event of influences detrimental to stability on fishing vessels of 21 September 1989, which are important as regards content but worded only in very general terms, must be observed. Added to this is the fact that these guidelines no longer have a direct claim of validity because the underlying provisions in UVV See were repealed.

The fishing vessel safety certificate issued by the Ship Safety Division (BG Verkehr) for the FV CONDOR in February 2015, which was valid at the time of the accident and certifies that the vessel complies with the requirements of the Guideline for fishing vessels in every respect, did not include a restriction, condition or provision with regard to compulsory use of the fish hold, either.

However, it is questionable in this context whether such a requirement would have actually been legally tenable on the basis of the currently valid Guideline for fishing vessels and/or given its legislative nature.

That important requirements affecting fishing vessel owners and even going beyond the content of the Guideline for fishing vessels are merely laid down in an internal administrative regulation of the Ship Safety Division (BG Verkehr) is also questionable.

As far as this also concerns the requirement to renew the proof of stability every ten years, it should also be considered that such a regulation is not necessarily expedient in terms of content, either.

The BSU believes that the following conclusions must be drawn from the above shortcomings:

- (1) unscheduled review of the proofs of stability of all vessels covered by the Guideline for fishing vessels;
- (2) ensure that this review is carried out using methods which rule out errors in the assessment of hydrostatic properties;<sup>44</sup>
- (3) review whether or to what extent the body of rules governing the registration and practical operation of vessels within the meaning of the Guideline for fishing vessels is actually legally sound in every respect. If necessary, establish a legally sound system based on the Ship Safety Act, the Ship Safety Ordinance, as well as the occupational health and safety regulations and accident prevention regulations applicable in Germany, and
- (4) with regard to the effective enforcement and monitoring of requirements pertaining to structural characteristics and stability, the BSU once more suggests that the condition of the vessel be photographically documented during scheduled or non-scheduled surveys, so as to better identify any structural modifications in subsequent monitoring. (The BSU already issued a related safety recommendation addressed to See-BG in 2008 as a consequence of the stability-related accident involving the German fishing vessel HOHEWEG, which claimed the lives of all four crew members.<sup>45</sup> It is regrettably the case that this has yet to be implemented.)

## **5.2 Failure of the liferaft**

The BSU's investigation has revealed unequivocally that the failure of the liferaft was due to faulty servicing. The manufacturer's instructions on which the servicing is based provide clear and unambiguous information on how the liferaft should be packed and repeatedly emphasise, in particular, the importance of ensuring that the combined painter/release cord is stowed in accordance with instructions so that it can glide out of the container freely.

The BSU is confident that the manufacturer of the liferaft places very high demands on the authorisation of service stations and the qualification of the staff working there.

The failure of the liferaft was therefore ultimately caused by the individual error of a single employee. Such human errors can never be ruled out or prevented entirely. This makes it all the more important to place particular emphasis on reducing to the greatest possible extent potential errors (especially those with serious

---

<sup>44</sup> See also in this respect the BSU's safety recommendations 7.1, 7.2 and 7.3 in Investigation Report 226/03 of 5 March 2004 on the very serious marine casualty involving the Foundering of FC NEPTUN on 30 July 2003 in the harbour entrance of Norddeich.

<sup>45</sup> See the BSU's safety recommendation 7.2 in Investigation Report 564/06 of 15 March 2008 on the very serious marine casualty involving the fishing vessel HOHEWEG on 8 November 2006 in the area of the Alte Weser west of Nordergründe.

consequences) when planning and designing equipment that is hazardous or relevant to safety from the outset.

With regard to the concept of the liferaft packed tightly inside a container, where the particular importance of the unconditional functioning of the painter/release cord is obvious, the manufacturer should consider changing the design in respect of the position of the painter/release cord and or the associated special sachet. The BSU believes that an optimum solution would be the development of a concept that does not require packing the special sachet (or any other form of packaging for the cord) with the liferaft more or less based on visual judgement, but to make it part of the container's internal design in a manner that ultimately renders a fatal error when packing the liferaft almost impossible.

Such an improvement in design is supported by the fact that in addition to the particular dangers associated with packing the painter/release cord incorrectly, there are also fears that there may be a high number of unreported cases of this defect across all manufacturers and that it is naturally not possible to check whether the painter/release cord is stowed properly inside a closed container. Moreover, it is not possible to check this on board, as an extracted cord can only be put back into the container during a shore-based service.

### **5.3 Failure of the EPIRB**

The EPIRB was most likely unable to float up to the surface after its mount opened hydrostatically on the day of the accident due to an obstruction caused by the fishing vessel or her equipment. The process of sending the distress signal probably started. However, the radio waves could not propagate sufficiently under water because of the system.

The BSU's investigations have revealed that the positioning of the EPIRB's mount on board the FV CONDOR satisfied both the practical requirements and the manufacturer's specifications.

Since it is neither possible to rule out a technical failure on an EPIRB nor the possibility that one may be prevented from reaching the surface for mechanical reasons, the BSU believes that the only logical conclusion to be drawn from the accident in this regard is to require redundancy in the future, i.e. duplication of the EPIRB system for vessels within the meaning of the Guideline for fishing vessels. The accident involving the FV CONDOR has dramatically demonstrated that a constructive total loss can occur at lightning speed in the case of small vessels, in particular. The generally very few crew members are not able to make a distress call or take the EPIRB off the vessel/manually activate it when ordered to abandon a distressed vessel in such situations. In view of the absolute necessity to set the rescue sequence in motion immediately, the aspect of an automated alarm system that works flawlessly becomes all the more important.



As regards an additional safeguard for automated activation of the rescue sequence, one alternative to a second EPIRB from a technical point of view would be to equip the lifejackets/floatation waistcoats used by crew members of small fishing vessels with a satellite- or AIS-based emergency transmitter, i.e. a PLB (personal locator beacon).

The advantage of such a solution over duplication of the conventional EPIRB system would be that when activated both the position of the accident and the casualty's actual position in the water would be transmitted to the rescue services. On the other hand, the disadvantage here is that the enhancement in safety is inevitably dependent upon crew members actually using their floatation waistcoats or carrying a PLB not integrated with a floatation waistcoat with them at all times, unlike the EPIRB.<sup>46</sup>

#### **5.4 Use of lifejackets and floatation waistcoats**

Regardless of the fact that it is highly unlikely that the use of a lifejacket or floatation waistcoat would have saved the two crew members in this specific case, the investigated facts demonstrate the incalculable value that wearing such a floatation aid can basically have in terms of lifesaving.

The requirement of crew members of German fishing vessels to wear a floatation waistcoat is dealt with in Article 262(7) UVV See and not affected by the vessel's size or area of operation. Quoted verbatim, it reads:

*"If, during work on deck, there is a danger of falling into the water, the ship's officer appointed for this matter shall ensure that approved working safety vests [sic] are worn. In the case of one-man operation, the approved working safety vest shall be worn at all times."*

According to the explanations given in the aforementioned regulation, dangerous work includes the deployment and retrieval of fishing gear, especially on stern trawlers during activities in front of and on the ramp, and the use of launches.

Based on the fishing activities on board the FV CONDOR, a legal obligation to wear a floatation waistcoat on board cannot be derived from the aforementioned accident prevention regulation. The risk of falling into the water during regular operations is very low on this type of fishing vessel with her relatively high railing.

---

<sup>46</sup> On the topic of PLBs, see the comments in sections 4.3 and 5.2, and especially the BSU's safety recommendations 6.1 and 6.2 of Investigation Report 262/14 of 12 April 2017 on the very serious marine casualty involving the 'Foundering of the fishing vessel ANDREA and death of a crew member in the Baltic Sea off Lippe on 16 August 2014' addressed to the Federal Ministry of Transport and Digital Infrastructure (BMVI) and the Ship Safety Division (BG Verkehr).

However, the accident shows that unforeseeable events may suddenly lead to a person overboard situation even in regular on-board operations.

Were we to assume that the FV CONDOR had foundered in summer water temperatures and/or the rescue sequence was set in motion much earlier due to a functioning EPIRB, then the risk of drowning and/or freezing to death would have been significantly lower had the crew members used a lifejacket or floatation waistcoat.

In this respect, it should be noted in general (i.e. regardless of the accident involving the FV CONDOR) that similar to recreational craft, the risk of falling overboard is significantly greater on relatively small fishing vessels due to their design and/or operation than on large cargo ships, for example.

Moreover, the fact that it would generally be extremely difficult for the low number of crew members on a small fishing vessel to assist a crew member overboard quickly and effectively should be rated as a factor that would increase risk in the coastal fisheries sector. This is especially true if the crew consists of only two people and the crew member remaining on board is required to carry out a return manoeuvre (possibly including handling the nets beforehand), make a distress call and cast a lifebuoy more or less simultaneously after such an accident possibly at night and in high swell.

This could be complicated by the difficulties involved in getting a crew member in the water back on board over a relatively high side. There is no doubt that the ability of accident victims to actively participate is lower if their energy is already largely depleted by the efforts they make to stay afloat.

Viewed in its entirety, the above reasoning supports stipulating the use of floatation waistcoats not only on board fishing vessels operated by one man or on stern trawlers in the area of the ramp, but also and in particular on small vessels used for coastal fishing.<sup>47</sup>

---

<sup>47</sup> On the topic of lifejackets on fishing vessels, see the comments in sections 4.2 and 5.2 of the BSU's Investigation Report 262/14 already mentioned in the footnote above.

## **6 Measures taken**

The liferaft manufacturer responded quickly and comprehensively, having previously participated unreservedly in the investigation into the cause of the failure of the liferaft.

The relevant service station in Denmark's certificate of approval has been withdrawn until further notice. In addition, a re-audit of this station was carried out locally and re-training was organised for the service engineers.

The manufacturer also gathered the data on all liferafts of the same configuration that were serviced by this service station and arranged for a recall of the liferafts for unscheduled inspection and servicing.

The manufacturer's technical department was instructed to consider changing the position of the painter/release cord sachet to avoid similar incidents in the future.

The manufacturer also sent a newsletter to all its authorised service stations to draw attention to the need to pack/stow the painter/release cord sachet for this type of liferaft correctly, explicitly referencing the relevant service manual in the process.

## 7 Safety recommendations

The following safety recommendations do not constitute a presumption of blame or liability in respect of type, number or sequence.

### 7.1 German Social Accident Insurance Institution for Commercial Transport, Postal Logistics and Telecommunication (Ship Safety Division (BG Verkehr))

#### 7.1.1 Review of the proofs of stability for all vessels covered by the 2009 Guideline for fishing vessels

The Federal Bureau of Maritime Casualty Investigation recommends that the Ship Safety Division (BG Verkehr) perform a thorough unscheduled review of the proofs of stability for all vessels covered by the Guideline for fishing vessels < 24 m in length.

#### 7.1.2 Review of the procedures for determining stability values

The Federal Bureau of Maritime Casualty Investigation recommends that the Ship Safety Division (BG Verkehr) carry out an overall review of the manner in which roll period and inclining tests are performed by its own surveyors or by third parties acting on its behalf and, in particular, their evaluation procedures with regard to the reliability of the results obtained and the procedures required to prepare realistic proofs of stability for vessels covered by the 2009 Guideline for fishing vessels.

### 7.2 Federal Ministry of Transport and Digital Infrastructure (BMVI); German Social Accident Insurance Institution for Commercial Transport, Postal Logistics and Telecommunication (Ship Safety Division (BG Verkehr)) – review of the national body of rules applicable to fishing vessels

The Federal Bureau of Maritime Casualty Investigation recommends that the BMVI and the Ship Safety Division (BG Verkehr) review the existing body of rules for the approval, surveying and certification of vessels covered by the Guideline for fishing vessels < 24 m in length (according to Article 6(1)(6) of the Ship Safety Ordinance) and, in particular, the Guideline itself for legal certainty and practicability. An analogous recommendation concerns whether and to what extent it may be necessary to reassert the special accident prevention regulations and related notices and guidelines that ceased to apply in the course of the amendment of the UVV See in 2011 with a view to guaranteeing occupational health and safety on the fishing vessels in question.

### **7.3 Federal Ministry of Transport and Digital Infrastructure (BMVI); German Social Accident Insurance Institution for Commercial Transport, Postal Logistics and Telecommunication (Ship Safety Division (BG Verkehr)) – renewal of proof of stability and photographic documentation of vessel surveys**

The Federal Bureau of Maritime Casualty Investigation recommends, with a view to enhancing the existing body of rules, that the BMVI and the Ship Safety Division (BG Verkehr) ensure, in particular, that proofs of stability are not only renewed at defined intervals but also whenever structural modifications are made that might affect the hydrostatic stability of the vessel in question. In this context, an obligation of photographic documentation during surveys should be introduced so as to make it easy to identify in subsequent surveys whether any structural modifications have been made in the meantime.<sup>48</sup>

### **7.4 Federal Ministry of Transport and Digital Infrastructure (BMVI) – revision of the carriage requirement for EPIRBs**

The Federal Bureau of Maritime Casualty Investigation recommends that the BMVI review the possibility of revising the carriage requirement for an EPIRB on vessels that fall within the scope of the Guideline for fishing vessels < 24 m in length (according to Article 6(1)(6) of the Ship Safety Ordinance). The equipment of two EPIRBs instead of one would mean a significant increase in safety for these vessels, in particular.

### **7.5 Survitec Group, Deutsche Schlauchboot**

The Federal Bureau of Maritime Casualty Investigation recommends that the Survitec Group in Birkenhead, Merseyside, England and its German subsidiary Deutsche Schlauchboot (DSB) in Eschershausen reconsider the structural design for the stowage of the combined painter/release cord and corresponding sachet in the containers of the self-inflating liferafts it produces. A concept should be developed in which the stowage of the cord is made in such a way as to rule out fatal human error to the greatest possible extent when the liferaft is packed after a service.

---

<sup>48</sup> See in this respect the BSU's safety recommendation 7.2 in Investigation Report 564/06 of 15 March 2008 on the very serious marine casualty involving the fishing vessel HOHEWEG on 8 November 2006 in the area of the Alte Weser west of Nordergründe.

## SOURCES

- Ship's file on the FV CONDOR, Ship Safety Division (BG Verkehr)
- Ship's file on the FV CONDOR, BSH, Hamburg
- Extract from the register for seagoing ships at Local Court Kiel
- Recordings of VTS Travemünde
- Information and recordings from the BLE – Fisheries Inspectorate
- Report on the dives on the wreck by divers from the BSH's survey, wreck search and research vessel DENEK, including video recordings of 15 February 2016
- Documentation and dive report from the FV CONDOR's salvage operation of 9 March 2016, Baltic Taucherei- und Bergungsbetrieb Rostock GmbH, including photographs and video recordings
- Interviews by the BSU
- Internet research by the BSU
- 3D laser scan of the FV CONDOR, Hamburg police, LKA 38 (phototechnology, graphics, crime scene reconstruction)
- Findings of the investigation of WSP Lübeck and the Kiel Public Prosecutor's Office
- Autopsy reports HL\_S038-16 and HL\_S037-16 (L2448-15) of the Institute of Forensic Medicine (Schleswig-Holstein University Clinic) of 11 February 2016
- Official report by Germany's National Meteorological Service (DWD) of 1 March 2016 on the weather and sea conditions in the western part of the Baltic Sea east of Fehmarn (54°25.5'N; 011°24.1'E) between 0600 UTC and 1400 UTC on 6 February 2016
- McMurdo QA report OBS13 – Sailor SGE 406 ii GPS EPIRB, 11 July 2016, McMurdo Group, Portsmouth, UK
- Information and technical documentation of DSB Deutsche Schlauchboot GmbH in Eschershausen (subsidiary of Survitec Group Limited, Birkenhead, Merseyside, England)
- Contact and technical assistance by iks Ingenieurbüro Klaas Schlenkermann, Wedel
- Contact and technical assistance by FURUNO DEUTSCHLAND GmbH, Rellingen
- Contact and technical assistance by Navico GmbH, Schleswig
- Contact and technical assistance by in-innovative navigation GmbH, Kornwestheim
- Contact with the insurance fund for fishing vessels in Lübeck Bay
- Contact and technical assistance by Mr Rüdiger Bornholdt (teacher at the vocational school for fish management in Rendsburg)
- Contact with the DGzRS/MRCC Bremen
- Contact with the Fehmarn fishermen's cooperative

- FV CONDOR investigation report dated 10 November 2016 concerning the technical equipment prepared on behalf of the BSU by Prof. Dipl.-Ing. Hark Ocke Diederichs, Timmaspe
- Expert opinion on the course and cause of the accident of 1 December 2016; assessment of the FV CONDOR's hydrostatic properties on behalf of the BSU by Sachverständigenbüro Dipl.-Ing. Jan Hatecke, Wischhafen
- Expert opinion # 02/16 on the accident involving the FV CONDOR of 26 June 2016 on behalf of the insurance fund for fishing vessels in Lübeck Bay, Captain Volker H. K. Kusche, naval architect (grad.), Bendestorf
- Essentials of Sea Survival; Frank Golden, Michael Tipton; Human Kinetics, Champaign, IL, United States; 2002
- Schiff und Manöver (ship and manoeuvre), publ. Prof. Dr. U. Scharnow, transpress, 3rd edition, Berlin 1987